

**Analyse der molekularen Grundlagen des  
männlichen Sozialverhaltens bei der  
Honigbiene *Apis mellifera***

Inaugural-Dissertation

zur Erlangung des Doktorgrades  
der Mathematisch-Naturwissenschaftlichen Fakultät  
der Heinrich-Heine-Universität Düsseldorf

vorgelegt von

**Sven Köhnen**  
aus Moers

Düsseldorf, März 2023

aus dem Institut für Evolutionsgenetik  
der Heinrich-Heine-Universität Düsseldorf

Gedruckt mit der Genehmigung der  
Mathematisch-Naturwissenschaftlichen Fakultät der  
Heinrich-Heine-Universität Düsseldorf

Berichtersteller:

1. Prof. Dr. Martin Beye

2. Prof. Dr. Laura Rose

Tag der mündlichen Prüfung: 03.07.2023

## **Eidesstattliche Erklärung**

Ich versichere an Eides statt, dass die Dissertation von mir selbständig und ohne unzulässige fremde Hilfe unter Beachtung der „Grundsätze zur Sicherung guter wissenschaftlicher Praxis an der Heinrich-Heine-Universität Düsseldorf“ erstellt worden ist. Die Dissertation wurde in der vorgelegten oder in ähnlicher Form noch bei keiner anderen Institution eingereicht. Ich habe bisher keine erfolglosen Promotionsversuche unternommen.

Duisburg, im März 2023

---

(Sven Köhnen)

## Inhaltsverzeichnis

<b>Kapitel I.....</b>	<b>6</b>
<b>Allgemeine Einleitung.....</b>	<b>7</b>
Verhaltensweisen der Honigbiene .....	8
Das Verhalten der Drohnen im Bienenstock.....	9
Das Gehirn der Honigbiene .....	10
Das olfaktorische System .....	12
Die Verarbeitung des Sexualpheromons 9-ODA in Drohnen.....	14
Die Geschlechtsbestimmung bei der Honigbiene .....	15
Der Tanskriptionsfaktor <i>fruitless</i> und seine Rolle bei der Spezifizierung männlichen Verhaltens .....	17
Zielsetzung .....	19
<b>Kapitel II: Manuskripte .....</b>	<b>21</b>
Manuscript I .....	22
<b><i>fruitless</i> specifies male group-living behaviors in the honeybee <i>Apis</i></b> <b><i>mellifera</i>.....</b>	<b>22</b>
Abstract .....	23
Introduction.....	24
Results .....	27
Discussion .....	35
Methods.....	40
Supplementary data .....	49
References .....	56
Author's Contribution: Manuscript I.....	63

Manuscript II .....	64
<b>The gene <i>fruitless</i> acts in a subset of the CNS to specify male social behaviors in honeybees.....</b>	<b>64</b>
Abstract .....	65
Introduction.....	66
Results .....	68
Discussion .....	76
Methods.....	81
Supplementary data .....	90
References .....	96
Author's Contribution: Manuscript II.....	101
<b>Kapitel III.....</b>	<b>102</b>
Zusammenfassung.....	103
Literaturverzeichnis .....	105
Danksagung.....	112

# Kapitel I

## Allgemeine Einleitung

Im Tierreich existiert eine enorme Bandbreite an Sozialität, die von solitär lebenden Organismen bis hin zu eusozialen Staaten reicht. Dabei ist der Grad der Sozialität mit der Häufigkeit von Interaktionen mit Artgenossen verknüpft. Während solitär lebende Organismen in bestimmten Lebensabschnitten, z. B. bei der Paarung oder der Brutpflege, soziale Verhaltensweisen zeigen können, ist das Leben in Gruppen durch ständige Interaktionen mit Gruppenmitgliedern gekennzeichnet.

Das Leben in Verbänden ermöglicht es diesen Arten, Ressourcen wie Nahrung effizienter zu nutzen und potenzielle Feinde abzuschrecken. In einigen Fällen erfolgt auch eine gemeinsame Aufzucht von Nachwuchs. Die Zusammensetzung und Struktur der sozialen Gruppen kann je nach Tierart sehr unterschiedlich sein. In einigen Fällen bilden Tiere innerhalb einer sozialen Gruppe eine Hierarchie, in der bestimmte Individuen dominant sind und andere untergeordnete Positionen einnehmen. So zeigen Bonobos eine matriarchalische Struktur, während Schimpansen eine patriarchalische Hierarchie aufweisen.

Es wird angenommen, dass die kognitiven Herausforderungen, die mit der Steuerung sozialer Interaktionen in diesen Gruppen verbunden sind, mit spezifischen und erweiterten Fähigkeiten der Informationsverarbeitung einhergehen. Dies wird damit begründet, dass viele Interaktionen gesteuert werden müssen, vielfältige Informationen aus Verhaltensbeziehungen einfließen, das soziale Verhalten ein größeres Repertoire und mehr Wahlmöglichkeiten bietet und das eigene Verhalten ständig angepasst werden muss (Humphrey, 1976; Dunbar, 1998; Pérez-Barbería et al., 2007; Dunbar, 2009; Albers, 2012; Weaverdyck and Parkinson, 2018). Andere Autoren hingegen argumentieren, dass die Verarbeitung von Interaktionen auch für solitär lebende Arten gilt und dass die höhere kognitive Leistungsfähigkeit von Tieren, die in Gruppen leben, auch auf andere Gründe zurückzuführen sein könnte. (Balter, 2012; Heyes, 2012; Benson-Amram et al., 2016; Farris, 2016; Kamhi et al., 2019).

Welche neuronalen und entwicklungsbiologischen Mechanismen diesen Verhaltensweisen zugrunde liegen und wie das zugrunde liegende genetische Programm evolviert ist, ist bisher kaum bekannt. Um die molekularen Grundlagen besser zu verstehen, sind Untersuchungen an Tieren mit ausgeprägtem Gruppenverhalten notwendig, die genetisch manipuliert werden können.

## Verhaltensweisen der Honigbiene

Eine besondere Form sozialer Gruppen sind eusoziale Staaten. Die Honigbiene gilt seit langem als Modellorganismus für die Erforschung eusozialen Verhaltens, vor allem wegen der vielfältigen Verhaltensweisen der sterilen Arbeiterinnen (Rösch, 1925; Seeley, 1986; Winston, 1987; Seeley, 1995). Die Aufgaben der Arbeiterinnen ändern sich mit dem Alter der Arbeiterinnen, was als zeitlicher Polyethismus bezeichnet wird. In den ersten Lebenstagen kümmern sich die Arbeiterinnen um die Reinigung der Zellen. Anschließend sind sie als Ammenbienen für die Pflege der Brut und der Königin zuständig. Als mittelalte Bienen beginnen sie mit der Verarbeitung von Nahrung, bis sie schließlich selbst zu Sammlerinnen werden und auf Nahrungssuche gehen (Lindauer and Watkin, 1953).

Die Hauptaufgabe der Drohnen und der Königin besteht in der Reproduktion. Geschlechtsreife Drohnen beginnen ab einem Alter von 7-9 Tagen mit kurzen Ausflügen, die dem Abkoten und der Orientierung dienen (Mariette et al., 2021). Kurze Zeit später unternehmen sie längere Ausflüge, bei denen sie sogenannte Drohnensammelplätze aufsuchen. An solchen Plätzen, die sich bis zu 40 Meter hoch in der Luft befinden können, sammeln sich Tausende von Drohnen aus bis zu 240 verschiedenen Kolonien (Baudry et al., 1998; Koeniger et al., 2005). Die genauen Charakteristika solcher Drohnensammelplätze sind nicht vollständig geklärt. Es wird vermutet, dass einerseits bestimmte Landschaftsmerkmale (Koeniger G, 2014), aber auch spezifisch männliche Pheromone eine Rolle spielen. So konnte nachgewiesen werden, dass fliegende Drohnen von den Extrakten anderer Drohnen angezogen werden (Lensky et al., 1985) und auch der Geruch lebender Drohnen hat im Labor eine anziehende Wirkung (Brandstaetter et al., 2014).

Die jungfräulichen Königinnen begeben sich mit etwas zeitlicher Verzögerung zu den Drohnen auf den sogenannten Hochzeitsflug, bei dem sie die Sammelplätze aufsuchen (Koeniger and Koeniger, 2004). Dort angekommen, beginnt ein Wettbewerb der Drohnen um die besten Positionen für die Begattung der Königin. Dabei spielt die Hauptkomponente des Königinnenpheromons, 9-oxo-(E)-2-decensäure (9-ODA), eine entscheidende Rolle (Mariette et al., 2021). Sowohl unter natürlichen Bedingungen (Gary, 1962; Brockmann et al., 2006) als auch im Labor (Brandstaetter et al., 2014) konnte gezeigt werden, dass 9-ODA anziehend auf Drohnen wirkt. Die Königin paart sich innerhalb von 15-30 Minuten mit bis zu 20



Drohnen, welche anschließend sterben (Woyke, 1955; Baudry et al., 1998; Schlüns et al., 2005). Sobald ihre Spermathek gefüllt ist, kehrt sie zu ihrer Kolonie zurück (Schlüns et al., 2005) und beginnt mit einer Verzögerung von etwa einer Woche mit der Eiablage. Für den Rest ihres Lebens legt sie bis zu 2000 Eier pro Tag (Page and Erickson, 1988).

### **Das Verhalten der Drohnen im Bienenstock**

Im Gegensatz zum Paarungsverhalten ist das Verhalten der Drohnen im Bienenstock nur wenig erforscht. Ein Grund dafür ist, dass Drohnen bis zu 70% ihres Lebens ruhend auf der Wabe verbringen (Free, 1957). Dennoch zeigen Drohnen auch Verhaltensweisen, die mit dem Leben in der sozialen Gruppe zusammenhängen. Die offensichtlichste dieser Verhaltensweisen ist das Fütterungsverhalten. Junge Drohnen nehmen Nahrung ausschließlich durch Trophallaxis auf (Free, 1957). Bei diesem Futteraustausch werden die Drohnen von Ammenbienen gefüttert. Um eine solche Fütterung auszulösen, betteln sie bei verschiedenen Arbeiterinnen, bis sie schließlich gefüttert werden. Ab einem Alter von ca. 6 Tagen nehmen sie zusätzlich Honig aus der Zelle auf und ernähren sich schließlich ausschließlich von den Honigvorräten (Free, 1957; Wachsmann and Crailsheim, 1994). Eine weitere Interaktion zwischen Drohnen und Arbeiterinnen ist das sogenannte Vibrieren. Dabei nähern sich Arbeiterinnen inaktiven Drohnen und erzeugen Vibrationssignale, die die Drohnen zur Aktivität anregen und so zu einer erhöhten Anzahl von Fütterungen führen. Interessanterweise werden hauptsächlich junge, nicht geschlechtsreife Drohnen auf diese Weise kontaktiert. Es wird daher vermutet, dass durch dieses Verhalten eine ausreichende Versorgung der Drohnen für eine normale Entwicklung hin zur Geschlechtsreife sichergestellt werden soll (Boucher and Schneider, 2009). Es stellt sich die Frage, wie die Arbeiterinnen zwischen jungen und älteren Drohnen unterscheiden können. Eine solche Unterscheidung kann ebenfalls beobachtet werden, wenn die Drohnen im Spätsommer aus dem Stock geworfen werden. Dabei werden zunächst ältere Drohnen von den Arbeiterinnen aus dem Stock entfernt (Free, 1957). Eine Hypothese diesbezüglich nimmt Bezug auf kutikuläre Kohlenwasserstoffe, organisch-chemische Substanzen, die auf der Oberfläche aller Insekten vorhanden sind. Tatsächlich konnte gezeigt werden, dass sich die Zusammensetzung dieser

kutikulären Kohlenwasserstoffe im Laufe der Entwicklung verändert (Wakonigg et al., 2000; Bastin et al., 2017). Bei den Arbeiterinnen verändert sich dieses Profil beim Übergang zur Sammelbiene deutlich, und es wird vermutet, dass diese Veränderungen einerseits mit einem erhöhten Schutz gegenüber Wasser einhergeht (Kather et al., 2011), aber auch eine wichtige Rolle bei der Erkennung von Gruppenmitgliedern spielt (Page et al., 1991; van Zweden and d’Ettorre, 2010).

Neben den oben genannten Verhaltensweisen benötigen die Drohnen weitere Anpassungen an das Leben im Stock, die keine direkte Interaktion beinhalten. Wie bereits erwähnt, führen die Arbeiterinnen viele verschiedene Tätigkeiten innerhalb des Stockes aus. Eine Anpassung an die soziale Umgebung des Bienenstocks beinhaltet, dass sich die Drohnen an bestimmten Stellen des Bienenstocks aufhalten, um die Koordination und Durchführung dieser Aktivitäten nicht zu behindern. Es ist bekannt, dass junge Drohnen sich tendenziell eher in der Mitte des Stocks, in der Nähe der Ammenbienen aufhalten, während ältere Drohnen sich eher in der Peripherie des Stocks aufhalten, wo vor allem Honigvorräte zu finden sind (Free, 1957; Wachsmann and Crailsheim, 1994). Drohnen sind außerdem aktiv an der Thermoregulation beteiligt und tragen so zur Erhaltung des Volkes bei (Kovac et al., 2009).

Die Evolution der Eusozialität bei der Honigbiene erforderte also eine Vielzahl von Verhaltensanpassungen, die in irgendeiner Weise spezifiziert worden sein müssen.

## **Das Gehirn der Honigbiene**

Der Ort, an dem Verhalten hauptsächlich spezifiziert wird, ist das zentrale Nervensystem. Das Gehirn der Honigbiene enthält etwa 960 000 Neuronen (Witthöft, 1967; Menzel and Giurfa, 2001; Menzel, 2012) und somit zwar ein Vielfaches mehr als beispielsweise das Gehirn der Fruchtfliege *Drosophila melanogaster* (Rein et al., 2002; Chiang et al., 2011; Milyaev et al., 2012). Dennoch ist es erstaunlich, über welche bemerkenswerten kognitiven Fähigkeiten sie verfügen, insbesondere in den Bereichen Navigation, Lernen und Gedächtnis (Menzel and Giurfa, 2001; Menzel, 2012). Die meisten Verhaltensweisen, wie etwa das Paarungsverhalten, das Sammeln von Futter oder die Kommunikation innerhalb der Kolonie, basieren auf der simultanen Integration mehrerer Sinnesmodalitäten (Thiagarajan and Sachse, 2022). Das Paarungsverhalten zum Beispiel, beruht wie bereits erläutert, auf der Integration von mindestens zwei

Sinnesmodalitäten, dem Sehen und dem Riechen. Zusammenfassend lässt sich sagen, dass die Fähigkeit, verschiedene Sinnesmodalitäten gleichzeitig zu integrieren, eine hohe Anpassungsfähigkeit an die Umwelt und eine effektive Kommunikation innerhalb der Kolonie ermöglicht.

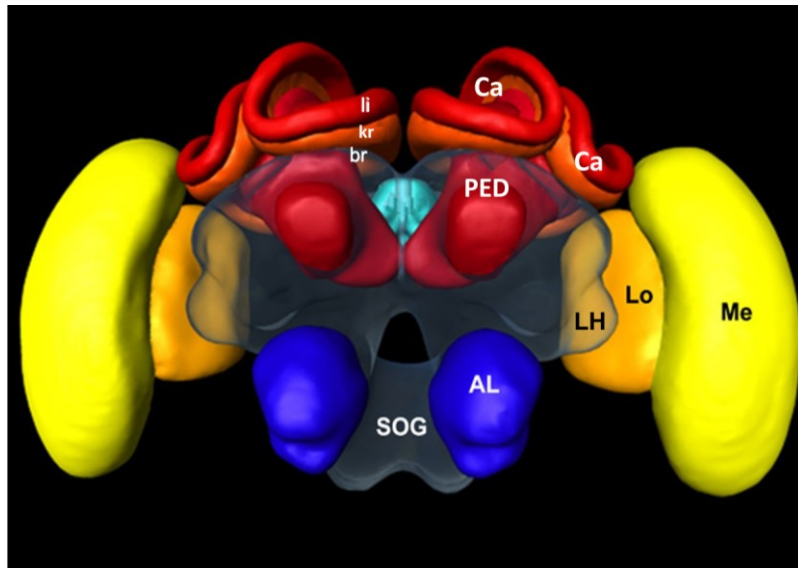

**Abbildung 1. Das Standardgehirn der Honigbiene.** Im suboesophagealen Ganglion (SOG) werden gustatorische und mechanosensorische Informationen prozessiert. In den Antennalloben (AL) werden olfaktorische Informationen aus der Antenne verarbeitet und an das laterale Horn (LH) und die Pilzkörpern (rot) weitergeleitet. Die Pilzkörper bestehen aus einem Pedunkel (PED), der die beiden Calyces (Ca), bestehend aus Lippe (li), Kragen (kr) und Basalring (br), verbindet. Im Kragen werden visuelle Informationen von den optischen Loben (gelb) verarbeitet, die aus der Lobula (Lo) und der Medulla (Me) bestehen. In der Lippe werden olfaktorische Informationen und im Basalring sowohl olfaktorische als auch gustatorische Informationen verarbeitet. Abbildung modifiziert nach Rybak et al. (Rybak et al., 2010).

Die Pilzkörper spielen eine wichtige Rolle im Gehirn der Honigbiene (Abbildung 1). Sie dienen als multimodale Integrationszentren und sind an Lern- und Gedächtnisprozessen beteiligt (Menzel, 1999; Hourcade et al., 2010; Menzel, 2012). Diese Strukturen befinden sich im dorsalen Teil des Gehirns und bestehen aus einem Paar becherförmiger Strukturen, den Calyces, die durch Pedunkel miteinander verbunden sind (Mobbs, 1982). Die Calyces lassen sich in drei Regionen unterteilen: Kragen, Lippe und Basalring, die multisensorischen Input erhalten (Mobbs, 1982). Im Kragen werden die visuellen Informationen der optischen Loben verarbeitet, die aus Lobula und Medulla bestehen (Mobbs, 1982). Die Lippe der Calyces empfängt olfaktorische Informationen von den Antennalloben (AL) und integriert diese (Mobbs,

1982). Der Basalring verarbeitet sowohl visuelle als auch olfaktorische Informationen (Mobbs, 1982; Abel et al., 2001).

Das laterale Horn (LH) ist dagegen weniger gut untersucht. Bei *D. melanogaster* wird vermutet, dass es sich um ein Integrationszentrum handelt, das angeborene Verhaltensweisen als Reaktion auf Duftstoffe induziert (Strutz et al., 2014; Dolan et al., 2019). Es konnte gezeigt werden, dass Fruchtduftstoffe in anderen Arealen verarbeitet werden als Pheromone (Jefferis et al., 2007; Strutz et al., 2014). Bei Arbeiterinnen konnte mittels Calcium Imaging gezeigt werden, dass verschiedene Duftstoffe unterschiedliche Aktivitätsmuster im LH auslösen. Dabei lösten verschiedene Pheromone wie das Alarmpheromon, das Königinnenpheromon oder Brutpheromone Aktivität in unterschiedlichen Bereichen aus. Es wäre daher denkbar, dass die verschiedenen Pheromone spezifische Verhaltensweisen im LH auslösen (Roussel et al., 2014).

Das suboesophageale Ganglion (SOG) spielt eine wichtige Rolle für den Geschmackssinn der Honigbiene. Es erhält Informationen von Neuronen, die Geschmacksrezeptoren exprimieren. Lediglich zehn Gene im Genom der Honigbiene kodieren für diese gustatorischen Rezeptoren (GR). Dies ist eine deutliche Reduktion im Vergleich zu *D. melanogaster* (Clyne et al., 2000; Dunipace et al., 2001; Scott et al., 2001; Robertson et al., 2003) und der Stechmücke *Anopheles gambiae* (Hill et al., 2002), die 68 bzw. 76 GRs besitzen. Obwohl die Geschmacksverarbeitung bei der Honigbiene hauptsächlich in den Mundwerkzeugen stattfindet, werden einige dieser GRs in den Antennen exprimiert. Es wird vermutet, dass diese Geruchsrezeptoren fungieren (Robertson and Wanner, 2006). Das SOG verarbeitet nicht nur Geschmacksinformationen, sondern auch mechanosensorische Informationen, die z.B. durch Berührungen mit den Antennen oder den Vorderbeinen entstehen. Es ist auch an der Steuerung motorischer Aktivitäten im Kopfbereich beteiligt (de Brito Sanchez, 2011).

## **Das olfaktorische System**

Das olfaktorische System spielt eine besondere Rolle für die soziale Kommunikation und das Verhalten im Bienenstock. In den Antennen exprimieren olfaktorische Rezeptorneuronen (ORN) verschiedene Chemorezeptoren, wie z.B. Geruchs- oder

Geschmacksrezeptoren. Olfaktorische Rezeptoren (OR), auch Geruchsrezeptoren genannt, wurden in *D. melanogaster* entdeckt (Clyne et al., 1999; Gao and Chess, 1999; Vosshall et al., 1999). Im Gegensatz zu *D. melanogaster* (Vosshall et al., 2000; Robertson et al., 2003) oder *A. gambiae* (Fox et al., 2001; Hill et al., 2002) mit 62 bzw. 79 ORs besitzt die Honigbiene mit 170 ORs eine deutlich höhere Anzahl dieser Rezeptoren. Es wird angenommen, dass diese Zunahme mit den besonderen olfaktorischen Fähigkeiten der Honigbiene zusammenhängt. Dazu gehören die Erkennung einer Vielzahl von floralen Duftstoffen zum Auffinden und Sammeln von Nektar und Pollen sowie die Erkennung verschiedener artspezifischer Pheromone (Robertson and Wanner, 2006).

Interessanterweise sind 24 dieser ORs in den Antennen der Drohnen stärker exprimiert als in denen der Arbeiterinnen, und es wird vermutet, dass sie an der Wahrnehmung von Sexualpheromonen beteiligt sind (Jain and Brockmann, 2020). Bei den Arbeiterinnen hingegen sind 67 ORs stärker exprimiert. Es wird angenommen, dass diese mit der Erkennung von Pheromonen, kutikulären Kohlenwasserstoffen und floralen Duftstoffen assoziiert sind (Jain and Brockmann, 2020).

Jedes olfaktorische Rezeptorneuron exprimiert nur einen Typ von OR, und sobald ein Duftmolekül an den OR bindet, wird ein elektrisches Signal an den Antennallobus (AL) weitergeleitet. Dieser ist das primäre Riechzentrum des Gehirns und besteht aus kugelförmigen Untereinheiten, den olfaktorischen Glomeruli. Jeder Glomerulus wird nur von einem ORN-Typ innerviert. Die Glomeruli werden außerdem von lokalen Interneuronen (LNs) innerviert (Witthöft, 1967), die sich ausschließlich in den Glomeruli verzweigen, diese miteinander verbinden und die ankommenden Signale verarbeiten (Sun et al., 1993; Galizia and Kimmerle, 2004). Jeder Duftstoff verursacht Aktivität in verschiedenen Glomeruli, was zu einem typischen kombinatorischen Aktivitätsmuster führt. Die Aktivitätsmuster für eine Vielzahl von Duftstoffen konnten mit Hilfe der Calcium Imaging Methode visualisiert werden (Joerges et al., 1997; Galizia et al., 1999; Sachse et al., 1999). Der dritte Neuronen Typ, der die Glomeruli innerviert, sind die Projektionsneuronen, die die verarbeiteten Informationen an höhere Verarbeitungszentren wie das laterale Horn oder die Pilzkörper weiterleiten (Witthöft, 1967; Flanagan and Mercer, 1989). Wie bei der Expression der OR in der Antenne gibt es auch bei den Antennalloben geschlechtsspezifische Unterschiede. Während Arbeiterinnen circa 165 Glomeruli besitzen (Arnold et al., 1985; Flanagan and Mercer, 1989), weisen Antennalloben von Drohnen circa 110 Glomeruli auf, von denen vier im

Vergleich zu Arbeiterinnen deutlich vergrößert sind und als Makroglomeruli bezeichnet werden (Arnold et al., 1985; Brockmann and Brückner, 1999; Brockmann and Brückner, 2001; Nishino et al., 2009; Bastin et al., 2018). Da eine ähnliche Struktur beim Tabakswärmer *Manduca sexta*, der makroglomeruläre Komplex, an der Detektion und Verarbeitung weiblicher Sexualpheromone beteiligt ist (Hansson et al., 1991), wird eine ähnliche Funktion für die Makroglomeruli in der Honigbiene angenommen.

### **Die Verarbeitung des Sexualpheromons 9-ODA in Drohnen**

Die Anziehungskraft von Königinnen auf Drohnen während des Hochzeitsfluges beruht auf verschiedenen Faktoren. Neben visuellen Reizen (Koeniger G, 2014) spielt auch 9-ODA eine entscheidende Rolle. Es ist der Hauptbestandteil des queen mandibular pheromone (QMP), auch Königinnenpheromon genannt (Butler et al., 1959). Es konnte gezeigt werden, dass Drohnen unter natürlichen und Laborbedingungen von 9-ODA angezogen werden (Gary, 1962; Brockmann et al., 2006; Brandstatter et al., 2014). Insbesondere jungfräuliche Königinnen haben einen höheren Anteil an 9-ODA im QMP, was zu einer erhöhten Attraktivität führt (Pankiw et al., 1996; Rhodes and Lacey, 2007; Villar et al., 2019).

Der olfaktorische Rezeptor 11 (OR11) hat eine hohe Affinität für 9-ODA und spielt daher vermutlich eine wichtige Rolle bei der Generierung von Paarungsverhalten (Wanner et al., 2007). ORNs, die OR11 auf ihrer Oberfläche exprimieren, innervieren den männchenspezifischen Makroglomerulus 2 (MG2) (Abbildung 2). Mittels Calcium-Imaging konnte gezeigt werden, dass 9-ODA in diesem Glomerulus Aktivität auslöst (Sandoz, 2006). Projektionsneurone leiten anschließend die verarbeitete Information aus den Antennalloben an das LH und die PK weiter (Abbildung 2).

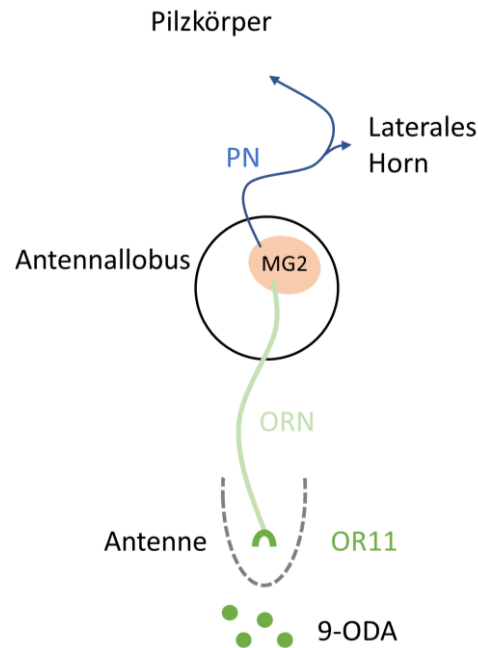

**Abbildung 2. Modell der Verarbeitung des Sexualpheromons 9-ODA in männlichen Honigbienen.** In den Antennen befinden sich olfaktorische Rezeptorneurone (ORNs), auf deren Oberfläche olfaktorische Rezeptoren (ORs) exprimiert sind. Sobald 9-ODA an OR11 bindet, wird ein elektrisches Signal vom olfaktorischen Rezeptorneuron zum Makroglomerulus 2 (MG2) weitergeleitet. Nach der Verarbeitung der Information im Antennallobus, leiten Projektionsneurone (PNs) das Signal an das laterale Horn und die Pilzkörper weiter. Abbildung modifiziert nach Mariette et al. (2021).

## Die Geschlechtsbestimmung bei der Honigbiene

Die Grundlagen für das unterschiedliche Verhalten und die Unterschiede zwischen den olfaktorischen Systemen von Arbeiterinnen und Drohnen werden bereits im Ei gelegt. Männliche Honigbienen entwickeln sich, im Gegensatz zu Arbeiterinnen und Königinnen, aus unbefruchteten und somit haploiden Eiern, was als Haplodiploidie bezeichnet wird (Abbildung 3A). Das initiale Signal für die Geschlechtsbestimmung ist das Gen *complementary sex determiner (csd)* (Beye et al., 2003). Haploide Eier enthalten lediglich ein *csd*-Allel und das daraus resultierende Csd-Protein hat keine regulatorische Funktion auf die Transkripte des *feminizer (fem)* Gens, was zu einem verkürzten, funktionslosen Fem-Protein führt (Hasselmann et al., 2008; Gempe et al., 2009). In der Abwesenheit funktioneller Fem-Proteine werden die Transkripte des Gens *doublesex (dsx)* männchenspezifisch gespleißt und das resultierende Protein Dsx<sup>M</sup> leitet die männliche Entwicklung ein (Gempe et al., 2009; Nissen et al., 2012).

Durch die Anwesenheit zweier verschiedener *csd*-Allele wird die *fem* prä-mRNA in diploiden Eiern weibchenspezifisch gespleißt, was zu einem funktionellen Fem - Protein führt. Unter der Kontrolle des Fem-Proteins wird die *dsx* prä-mRNA weibchenspezifisch gespleißt und Dsx<sup>F</sup> induziert die weibliche Entwicklung.

Das Gen *dsx* spielt eine wichtige Rolle bei der Entwicklung geschlechtsspezifischer Merkmale bei Insekten. Bei Honigbienen ist Dsx<sup>F</sup> für die korrekte Entwicklung der weiblichen Reproduktionsorgane essentiell. Mutationen in *dsx* können zu Entwicklungsstörungen und verkleinerten Ovarien führen, wie bei *dsx*-mutierten Puppen beobachtet wurde (Roth et al., 2019). Auch bei anderen Insektenarten, wie *D. melanogaster* (Camara et al., 2019), *Bombyx mori* (Xu et al., 2017) oder *Nilaparvata lugens* (Zhuo et al., 2018) wurde ein Zusammenhang zwischen einer fehlerhaften Entwicklung der Fortpflanzungsorgane und *dsx* festgestellt.

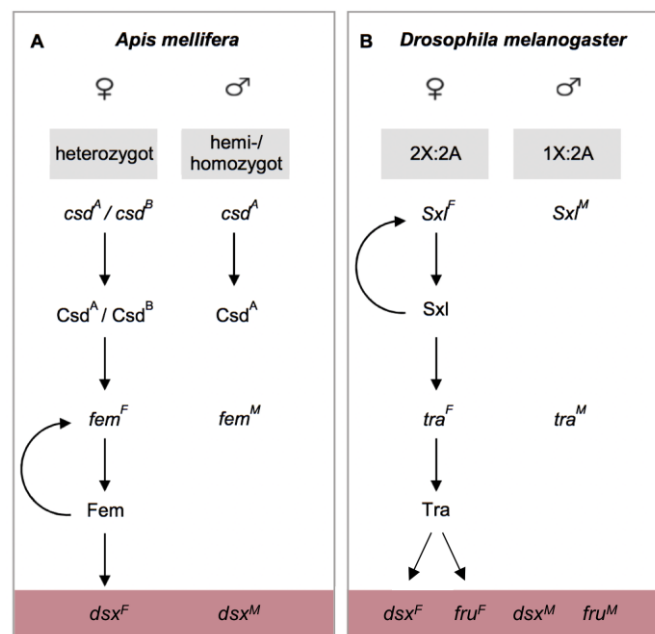

**Abbildung 3. Darstellung der Geschlechtsbestimmung bei *Apis mellifera* (A) und *Drosophila melanogaster* (B).** Bei *A. mellifera* bestimmt der Allelzustand von *csd* das Geschlecht, bei *D. melanogaster* das Verhältnis von Autosomen- zu Geschlechtschromosomen. In Weibchen regulieren die Transkriptionsfaktoren *complementary sex determiner* (*csd*) bzw. *sex-lethal* (*sxl*) das geschlechtsspezifische Spleißen der Orthologe *feminizer* (*fem*) bzw. *transformer* (*tra*). Die Proteine Fem und Tra wiederum sorgen für das weibliche Spleißen von *doublesex* (*dsx*). Bei *D. melanogaster* reguliert Tra zusätzlich noch das Spleißen von *fruitless* (*fru*). Das männchenspezifische Spleißen von *fem* bzw. *tra* und *dsx* bzw. *fru* erfolgt standardmäßig in Abwesenheit von Csd bzw. Sxl. Fem und Sxl erhalten das Spleißen ihrer eigenen prä-mRNA durch positive Autoregulation aufrecht. Abbildung modifiziert und ergänzt nach Netschitailo (2020).



Der Funktionsverlust von Dsx<sup>F</sup> bei weiblichen Gelbfiebermücken der Art *Aedes aegypti* (Mysore et al., 2015) oder der Stechmücke *Anopheles gambiae* (Kyrou et al., 2018) führt zu einer fehlerhaften Entwicklung der Mundwerkzeuge und Antennen. Bei *D. melanogaster* konnte zudem gezeigt werden, dass die geschlechtsspezifische Pigmentierung (Kopp et al., 2000; Williams et al., 2008) und die Entwicklung der männchenspezifischen Borsten an den Vorderbeinen (Devi and Shyamala, 2013; Rice et al., 2019) durch *dsx* beeinflusst werden. Interessanterweise hat *dsx* auch Einfluss auf das männliche Paarungsverhalten bei *D. melanogaster* (Kimura et al., 2008). Ein weiterer Transkriptionsfaktor, *fruitless*, spielt ebenfalls eine wichtige Rolle bei der Spezifizierung des männlichen Paarungsverhaltens.

### **Der Transkriptionsfaktor *fruitless* und seine Rolle bei der Spezifizierung männlichen Verhaltens**

Das Gen *fruitless* (*fru*) ist Teil der Geschlechtsdeterminationskaskade von *D. melanogaster* (Abbildung 3B). Das Geschlecht wird durch das Verhältnis der Autosomensätze zu den X-Chromosomen bestimmt. Bei einem Verhältnis von 1:1 entwickeln sich Weibchen, bei einem Verhältnis von 1:2 Männchen. Das weibchenspezifische Transkript des Gens *Sex-lethal* (*Sxl*) führt zu einem funktionellen Protein, welches das weibchenspezifische Spleißen des Gens *transformer* (*tra*) kontrolliert. Die Anwesenheit des Tra-Proteins führt wiederum zu weiblichen Transkripten der Gene *dsx* und *fru*. Das männliche *Sxl*-Transkript führt zur Abwesenheit eines funktionsfähigen Tra-Proteins und damit zu männlichen *dsx*- und *fru*- Transkripten. *Tra* und *dsx* sind ortholog zu *fem* und *dsx* in der Honigbiene. Trotz des unterschiedlichen initialen Signals, ist die Kaskade zwischen diesen beiden Arten relativ gut konserviert.

Der Transkriptionsfaktor *fru* wird von vier verschiedenen Promotoren transkribiert, aber nur das Transkript des distalen Promotors (P1) wird geschlechtsspezifisch gespleißt (Abbildung 4; Ito et al., 1996; Ryner et al., 1996; Heinrichs et al., 1998). Das Gen besitzt drei alternative C-terminale Exons, die jeweils für eine Zink-Finger-Domäne kodieren. Darüber hinaus besitzt es eine BTB (Broad-Complex, Tramtrack and Bric a brac)- Domäne, die in allen Transkripten vorhanden ist (Zollman et al., 1994; Ito et al., 1996; Ryner et al., 1996). Bei Männchen wird ein vorzeitiges Stoppcodon

standardmäßig herausgespleißt, was zu einem funktionellen Fru<sup>M</sup>-Protein einschließlich der BTB- und Zink-Finger-Domäne führt. Bei Weibchen wird *fru* unter der Kontrolle des Transkriptionsfaktors *transformer*, eines Orthologs von *fem*, gespleißt (Heinrichs et al., 1998). Die resultierende mRNA enthält das vorzeitige Stoppcodon, was zu einem verkürzten, funktionslosen Protein führt. Die Transkripte und die daraus resultierenden Proteine der anderen Promotoren sind in beiden Geschlechtern vorhanden (Anand et al., 2001; Song et al., 2002; Dornan et al., 2005). Männliche Tiere mit einer Mutation in *fru*, die Fru<sup>M</sup> nicht exprimieren, verlieren ihr normales Paarungsverhalten. Wird Fru<sup>M</sup> hingegen in ansonsten weiblichen Individuen exprimiert, führt dies zur Ausbildung männlichen Paarungsverhaltens. Es konnte somit gezeigt werden, dass ein einzelnes Gen wesentliche Aspekte eines komplexen Verhaltens spezifiziert (Demir and Dickson, 2005).

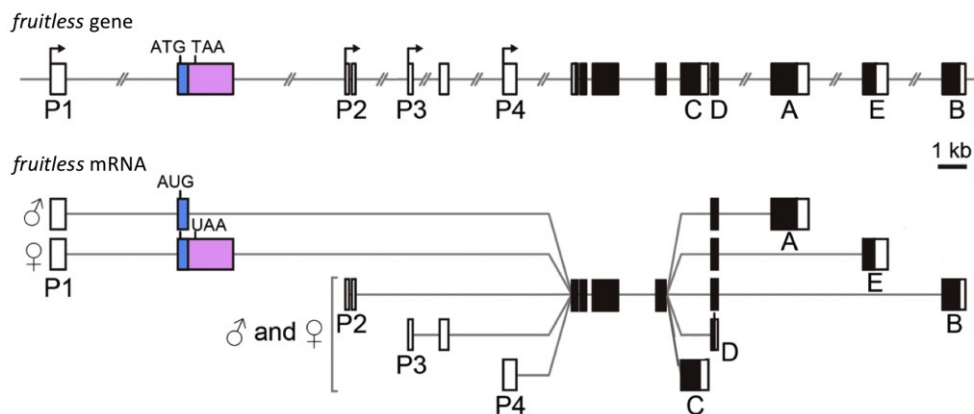

**Abbildung 4. Schematische Darstellung der Struktur des *fruitless*-Gens (*fru*).** Dargestellt sind die vier Promotoren (P1-P4) und die Exon-Intron-Organisation. Schwarze und weiße Kästen kennzeichnen kodierende und nicht-kodierende Exons. Das zweite Exon unterliegt dem geschlechtsspezifischen Spleißen und ist farblich markiert. A-E kennzeichnen alternative C-terminale Exons. Die Start- und Stoppcodons sind ebenfalls eingezeichnet. (B) Mögliche Spleißvarianten von *fru*. Der Teil von Exon2, der das Stoppcodon enthält, wird bei männlichen Tieren herausgespleißt. Die Produkte der Promotoren 2-4 sind geschlechtsunspezifisch. Abbildung modifiziert nach Sato et al. (2019).

Fru<sup>M</sup> wird während der Entwicklung im Zentralnervensystem der Männchen exprimiert, aber nicht in dem der Weibchen (Lee et al., 2000). Insgesamt wird es in etwa 2000 Neuronen exprimiert, wobei diese Neuronen häufig so genannte Cluster bilden (Lee et al., 2000; Usui-Aoki et al., 2000). Einige dieser Cluster sind nur in männlichen

Gehirnen vorhanden, einige unterscheiden sich zwischen Männchen und Weibchen, die meisten sind jedoch bei beiden Geschlechtern vorhanden (Kimura et al., 2005; Stockinger et al., 2005; Kimura et al., 2008). Die korrekte Entwicklung des männchenspezifischen Clusters P1 hängt sowohl von *fru<sup>M</sup>* als auch von *dsx<sup>M</sup>* ab (Kimura et al., 2008).

Interessanterweise sind Struktur und das geschlechtsspezifische Spleißen von *fru* in verschiedenen Insektenarten konserviert, darunter in Wespen (Bertossa et al., 2009), in Stechmücken (Gailey et al., 2006; Salvemini et al., 2013; Basrur et al., 2020) und Stubenfliegen (Meier et al., 2013). Auch bei der Gelbfiebermücke *Aedes aegypti* (Basrur et al., 2020) und dem Seidenspinner *Bombyx mori* (Xu et al., 2020) konnte ein Einfluss auf das männliche Verhalten nachgewiesen werden.

## Zielsetzung

Soziale Verbände sind in der Tierwelt weit verbreitet und bieten zahlreiche Vorteile, wie etwa eine bessere Verteidigung gegen Feinde oder eine höhere Effizienz bei der Nahrungssuche. Die Interaktionen innerhalb solcher Gruppen sind jedoch komplex, und ihre molekularen Grundlagen sind noch weitgehend unverstanden.

Obwohl eine Vielzahl von Genen für ein Verhalten notwendig ist, da sie für die allgemeine Funktion der Neuronen essentiell sind, wurden einzelne Gene identifiziert, die das Potenzial für ein bestimmtes Verhalten während der Entwicklung festlegen.

Das Fru Protein ist ein wichtiger Faktor für das männliche Paarungsverhalten bei *D. melanogaster* und spielt ebenfalls eine Rolle bei der Spezifizierung von männlichem Verhalten in der Gelbfiebermücke *Aedes aegypti* (Basrur et al., 2020) und im Seidenspinner *Bombyx mori* (Xu et al., 2020). Geschlechtsspezifisches Spleißen führt bei Männchen zu einem aktiven Fru-Protein, während bei Weibchen nur ein verkürztes, funktionsloses Protein produziert wird. Dieses geschlechtsspezifische Spleißen ist auch bei anderen Insektenarten wie Wespen, Mücken und der Stubenfliege konserviert.

Im Gegensatz zu den Männchen dieser Insektenarten, zeigen männliche Honigbienen zusätzlich zum Paarungsverhalten, Verhaltensweisen, die der Anpassung an das Leben im sozialen Staat dienen. Sie interagieren ständig mit sterilen Arbeiterinnen und lassen sich beispielsweise von diesen füttern.

In dieser Arbeit soll untersucht werden, welche molekularen Grundlagen diesen evolutionären Anpassungen zugrunde liegen und ob das konservierte Gen *fruitless* Einfluss auf dieses Verhalten hat. Es wird dabei der Frage nachgegangen, ob ein einzelnes Gen ausreicht, um diese Verhaltensweisen zu spezifizieren, und ob es spezielle neuroanatomische und molekulare Merkmale gibt, die speziell für diese Verhaltensweisen zuständig sind.

Zu diesem Zweck soll zunächst das Gen *fruitless* in der Honigbiene charakterisiert werden. Mit Hilfe des CRISPR/Cas9-Systems wird anschließend eine Deletion induziert, die zu einem Funktionsverlust in Männchen führt. Anschließend soll das Verhalten der mutierten Drohnen in einer kleinen Kolonie mit Hilfe computergestützter Methoden analysiert werden. Im zweiten Teil dieser Arbeit wird das Expressionsmuster im Gehirn und die Wirkung auf das olfaktorische System untersucht, um die Funktionsweise von *fruitless* in Männchen zu verstehen. Hierzu soll membrangebundenes grün fluoreszierendes Protein (GFP) unter der Kontrolle des endogenen P1-Promotors exprimiert werden, um die Projektionsmuster der *fru<sup>M</sup>*-exprimierenden Neuronen und ihre Beteiligung an verschiedenen Sinnesmodalitäten aufzudecken. Um den Einfluss von *fru* auf das olfaktorische System zu analysieren, wird die Expression von Chemorezeptoren in der Antenne mittels RNASeq analysiert und die neuronale Repräsentation verschiedener Duftstoffe und Pheromone im Antennallobus mittels Calcium-Imaging untersucht.

## **Kapitel II: Manuskripte**

## Manuskript I

### ***fruitless* specifies male group-living behaviors in the honeybee *Apis mellifera***

Sven Köhnen<sup>1</sup>, Miriam Müller<sup>1</sup>, Pia Ulbricht<sup>1</sup>, Thomas Eltz<sup>2</sup> and Martin Beye<sup>1</sup>

<sup>1</sup> Institute of Evolutionary Genetics, Heinrich-Heine University, Dusseldorf, Germany

<sup>2</sup> Department of Animal Ecology, Evolution and Biodiversity, Ruhr-University,  
Bochum, Germany

Journal: Manuscript in preparation for submission to "Cell"

**Abstract**

While there are benefits to living in a group, there are also cognitive challenges. Individuals must process a multitude of social interactions and constantly adapt their behavior to group dynamics. Despite the importance of group-living behaviors for social cohesion and survival, our understanding of their neural and developmental underpinnings remains limited. Here, using CRISPR/Cas9, we found that *fruitless*, a transcription factor essential for male courtship behavior in *Drosophila melanogaster* and conserved across insects, specifies aspects of group-living behaviors in honeybee males. Using the Bee Behavioral Annotation System (BBAS), we show that loss of male-specific *fruitless* gene expression significantly reduces the frequency of begging and trophallaxis, suggesting that *fruitless* is involved in initiating interactions. We further infer that aspects of mating behavior are also specified by *fruitless*, as the response to the sex-pheromone 9-ODA was also impaired in another behavioral assay. Our results provide evidence that a single gene specifies important aspects of group-living and mating behaviors in male honeybees, suggesting that an ancestral gene has been co-opted for the adaptation to the life in a social environment.

## Introduction

Behaviors are strikingly different between females and males contributing the astonishing behavioral diversity among animal organisms. In group-living animals, these sex dimorphic differences are not only limited to the courtship and mating behaviors, but they significantly shape the social relationships within the groups, from invertebrates to vertebrates. The many behavioral interactions between the sexes generate matriarchal social structures in bonobos and matriarchal hierarchies in chimpanzees in social groups that change in size and composition over time (fission-fusion societies). At the other end of the spectrum, we find cooperative behavior among group members, as in the division of reproduction in colonies of honeybees, ants, and naked mole rats (eusocial societies).

It has been suggested that the cognitive challenges of controlling the social interactions in these groups may require specific and expanded information processing abilities. This is due to the requirements to control many interindividual interactions, the diversified information inputs from behavioral relationships, the greater repertoire and choices attributed to social behaviors and the constant behavioral adjustments (Dunbar, 2009; Albers, 2012; Lihoreau et al., 2012; Avargues-Weber et al., 2018; Weaverdyck and Parkinson, 2018; Godfrey and Gronenberg, 2019). Other authors, however, have argued that this processing is not unique, as solitary animals also acquire information from other animals and the greater cognitive capacity is required for other purposes (Heyes, 2012; Benson-Amram et al., 2016; Kamhi et al., 2019). However, our understanding of the neuronal and developmental mechanisms underlying group-living behaviors is rudimentary at best.

If we are to understand the control of group-living behaviors at the molecular and cellular level, we must examine animals that exhibit elaborate social behaviors and that can be genetically manipulated. For this purpose, the honeybee (*Apis mellifera*) provides the ideal combination of innate, well-described social behaviors with a rich body of literature (von Frisch, 1967; Seeley, 1982; Johnson, 2008), computer-based tracking of colony members (Blut et al., 2017; Gernat et al., 2018; Smith et al., 2022) and powerful methods for genetic manipulation (Schulte et al., 2014; Roth et al., 2019; Wagner et al., 2022).

The maintenance and reproduction of honeybee colonies is based on the numerous contacts between colony members and their interactions with the shared social



environment. A typical honeybee colony consists of the reproductive queen, thousands of usually sterile worker bees and hundreds of males. Of all male behaviors, feeding behavior is the most characteristic innate group-living behavior (Free, 1957b; Ohtani, 1974). Young males do not feed on the pollen and honey stored in the cells of the comb. Instead, they receive food from the worker bees, which requires a sequence of behaviors (Ohtani, 1974). The males frequently approach the worker bees to beg for food, and the worker bees eventually provide liquid food from their honey stomach, an expandable part of their stomach, to the males via mouth-to-mouth transfer (trophallaxis behavior). However, how this group-living behavior is developmentally programmed into the brain is unknown.

Sexual behaviors in honeybees occur outside the colony, where thousands of drones form congregations waiting for virgin queens to mate with them. Within the congregation, drones are thought to be attracted to queens by the queen pheromone component 9-oxo-(E)-2-decenoic acid (9-ODA) (Butler et al., 1959; Butler et al., 1962). 9-ODA serves as an attractant for drones under both natural conditions (Gary, 1962; Brockmann et al., 2006) and in the laboratory (Brandstaetter et al., 2014), and elicits activity in male-specific macroglomerulus 2 (MG2) of the antennal lobe (Sandoz, 2006; Carcaud et al., 2015).

Although a vast majority of genes are possibly required for a behavior as they are essential for the general functioning of neurons, some genes have been identified that act during development to specify the potential for a particular behavior. A vertebrate candidate gene for such developmental programming is the forkhead domain transcription factor gene, FoxP2, which is possibly involved in speech ability in humans and specifies social behaviors associated with neuronal dendrite length in the brain in mice (Vargha-Khadem et al., 1998; Groszer et al., 2008; Enard et al., 2009; Reimers-Kipping et al., 2011; Medvedeva et al., 2019). In *Drosophila melanogaster*, mating behaviors are "hardwired" into the nervous system via the action of the ZnF domain transcription factor gene *fruitless (fru)* (Auer and Benton, 2016; Rings and Goodwin, 2019). P1 *fru* transcripts are sex-specifically spliced, resulting in the expression of a functional Fru protein only in male neuronal tissues (Ito et al., 1996; Ryner et al., 1996; Demir and Dickson, 2005). This male-specific Fru protein (Fru<sup>M</sup>) regulates the differentiation of an anatomically and molecularly sexually dimorphic nervous system (Kimura et al., 2005; Kimura et al., 2008; Palmateer et al., 2023). Different sensory inputs promote the selection of a subset of *fru*-expressing neurons that control male

courtship behavior toward females and aggression behavior toward other males (Kurtovic et al., 2007; Billeter et al., 2009; Wang et al., 2011; Kohatsu and Yamamoto, 2015; Zhou et al., 2015; Versteven et al., 2017; Ribeiro et al., 2018). The *fru* gene is sex-specifically spliced in phylogenetic diverse insect groups; in wasps (Bertossa et al., 2009), mosquitoes (Gailey et al., 2006; Salvemini et al., 2013; Basrur et al., 2020), houseflies (Meier et al., 2013), and medflies (Davis et al., 2000; Salvemini et al., 2009). Furthermore, it is required to program male mating behaviors in the mosquito *Aedes aegypti* (Basrur et al., 2020) and the silkworm *Bombyx mori* (Xu et al., 2020), suggesting a conserved role of the male gene product in specifying male sexual behaviors in insects.

Are major aspects of group-living behaviors also developmentally programmed by a single gene, as found for the sexual behaviors?

Are the group-living behaviors controlled by similar neuronal processes as the sexual behaviors?

Are there unique neuronal anatomical and molecular features that are specifically dedicated to the group-living behaviors?

Male group-living behavior in the honeybee colony provides a rare opportunity to further test these hypotheses. A place to look for a developmental regulator of male group-living behavior is the sex determination pathway. Sexual development in honeybees is regulated by the hetero-/hemizygous *complementary sex determiner* (*csd*) gene (Beye et al., 2003), which directs the male splicing of the *feminizer* (*fem*) transcripts to include an early translational stop codon (Hasselmann et al., 2008; Gempe et al., 2009a). *Fem* is an ortholog of the *transformer* (*tra*) gene (Butler et al., 1986; McKeown et al., 1987; Pane et al., 2002). This male *fem* transcripts encode a non-functional version of the *fem* protein, resulting in the default splicing of the developmental regulators *doublesex* (*dsx*) and *glubschaug* (*glu*) (Roth et al., 2019; Netschitailo et al., 2023). To identify other male-specific developmental regulators that program the potential for the male-specific behaviors, we screened for further transcripts that are spliced male-specific and express a transcriptional regulator in the male brain. We identified *fru* transcripts, but no additional sex-specific spliced transcription factor genes in male pupae (Vleurinck et al., 2016). Therefore, we set out to characterize the role of the *fru* gene in programming group-living behaviors in the neuronal substrate of the male bees.

## Results

### *fru*<sup>M</sup> transcript specifies social feeding behavior in males

To understand whether the group-living behaviors of the males are specified by the *fru* gene, we generated loss-of-function *fru* alleles, targeting the male-specific transcripts (*fru*<sup>M</sup>) and proteins (Fru<sup>M</sup>) and examined the social behaviors of the mutants in small colonies.

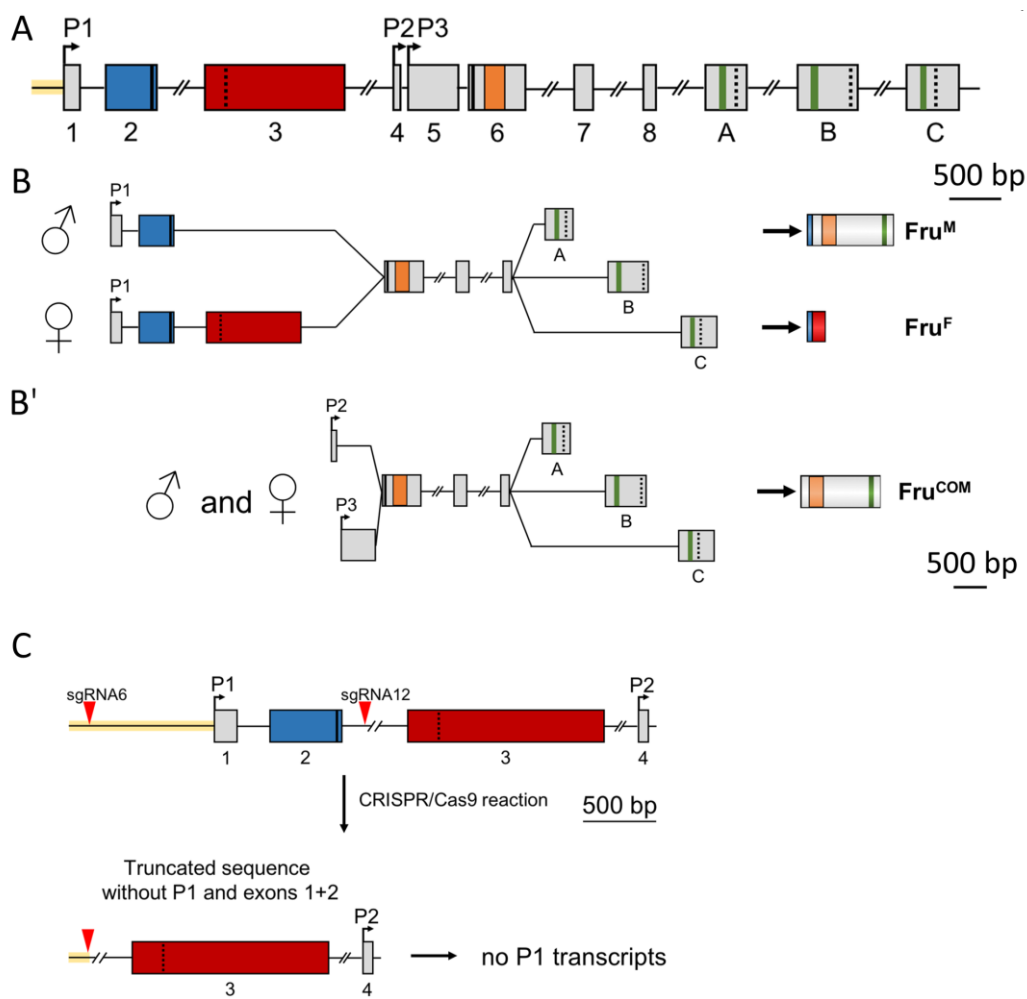

**Figure 1. The structure of the *Am-fruitless* gene and the generation of *fruP1<sup>-</sup>* mutants.** **A:** Organization of the *fru* genomic locus. Boxes indicate exons. P1, P2 and P3 are alternative promoters. A, B and C are alternatively used exons with zinc finger domains (green). BTB domain (orange), translation start (vertical line) and stop (vertical dashed line) are indicated. **B:** Coding sequence of sex-specific P1 transcripts expressing sex-specific proteins. **B':** Coding sequence of P2 and P3 transcripts expressing common proteins. **C:** Generation of *fruP1<sup>-</sup>* males by introducing a deletion in the *fru* genomic locus. Arrow (red) indicates target sites of sgRNAs 6 and 12.

Our detailed transcript analysis in honeybees showed that the *fru* gene is transcribed from at least three promoters of which only the P1 transcripts are sex-specifically spliced (Fig. 1A). The male-specific transcripts encode a set of proteins with 386 to 459 amino acids (Fig. 1B). The three protein variants share an N-terminal BTB (for Broad-Complex, tramtrack and Bric-à-brac) domain, but have three alternative zinc finger (ZnF) domains derived from alternatively spliced exons. The early stop codon in the female-specific transcripts (*fru<sup>F</sup>*) produces only a short coding sequence that would lack the BTB and ZnF domains in the expressed protein (Fig. 1B). RNAi-mediated knockdown showed that the sex-specific splicing of *fru* transcripts is controlled by the *feminizer* (*fem*) gene (Supplementary Fig. S1), an upper key component of the sex determination pathway (Hasselmann et al., 2008; Gempe et al., 2009b). P2 and P3 transcripts are non-sex-specific but alternatively spliced transcripts that express again three protein variants with a common BTB domain but three alternative ZnF domains (Fig. 1B').

We deleted the P1 promoter together with exons 1 and 2 using CRISPR/Cas9-induced deletion (Jinek et al., 2012; Roth et al., 2019) in queens to obtain males without male-specific P1 transcripts (Fig. 1 C, Supplementary Fig. S3). The *fruP1<sup>-</sup>* males are derived from unfertilized eggs and they are haploid with a hemizygous *complementary sex determiner* (*csd*) gene (Beye et al., 1999; Beye et al., 2003). We developed a Fru antibody (binding to parts of the BTB-domain and exons 6 and 7) and observed in immunostained brains, that expression is present in wildtype (wt) males but is absent in females (Fig. 2B). The male-specific expression of the Fru proteins was specifically absent in *fruP1<sup>-</sup>* males (Fig. 2B). The Anti-Fru protein staining was localized to the nucleus, consistent with its proposed function as a transcription factor (Supplementary Fig. S2). Collectively, we have shown that Fru proteins are exclusively expressed in male brains and that the *fruP1<sup>-</sup>* mutation in the males specifically causes a loss of P1 transcripts and a loss of male-specific Fru protein expression.

To study the behaviors, we introduced newly emerged *fruP1<sup>-</sup>* and wt males into a small colony consisting of 460 worker bees, a queen and a comb (Fig. 2A). The cells of the comb were either filled with pollen, honey or were empty as in natural colonies. In this experiment, however, the number of cells and the areas containing food were standardized (Supplementary Fig. S4). Males were individually labeled with two-dimensional barcodes and computer-based tracked using the Bee Behavioral Annotation System (BBAS; Blut et al., 2017) when they were two days old.

Central to the behavioral adaptation of males to group-living is that they are fed by worker bees. Males do not feed independently from collective honey food stores until they are older than 4 days (Free, 1957a; Wachsmann and Crailsheim, 1994). They beg workers for food, which eventually leads to trophallaxis and transfer of liquid food. To get knowledge whether the *fru<sup>M</sup>* transcript specifies this social feeding behavior we examined *fruP1<sup>-</sup>* males in the colony. We found that they performed the same action patterns of begging and trophallaxis behaviors as wt males, suggesting that stereotypic execution was not compromised (Supplementary Videos V1-4).

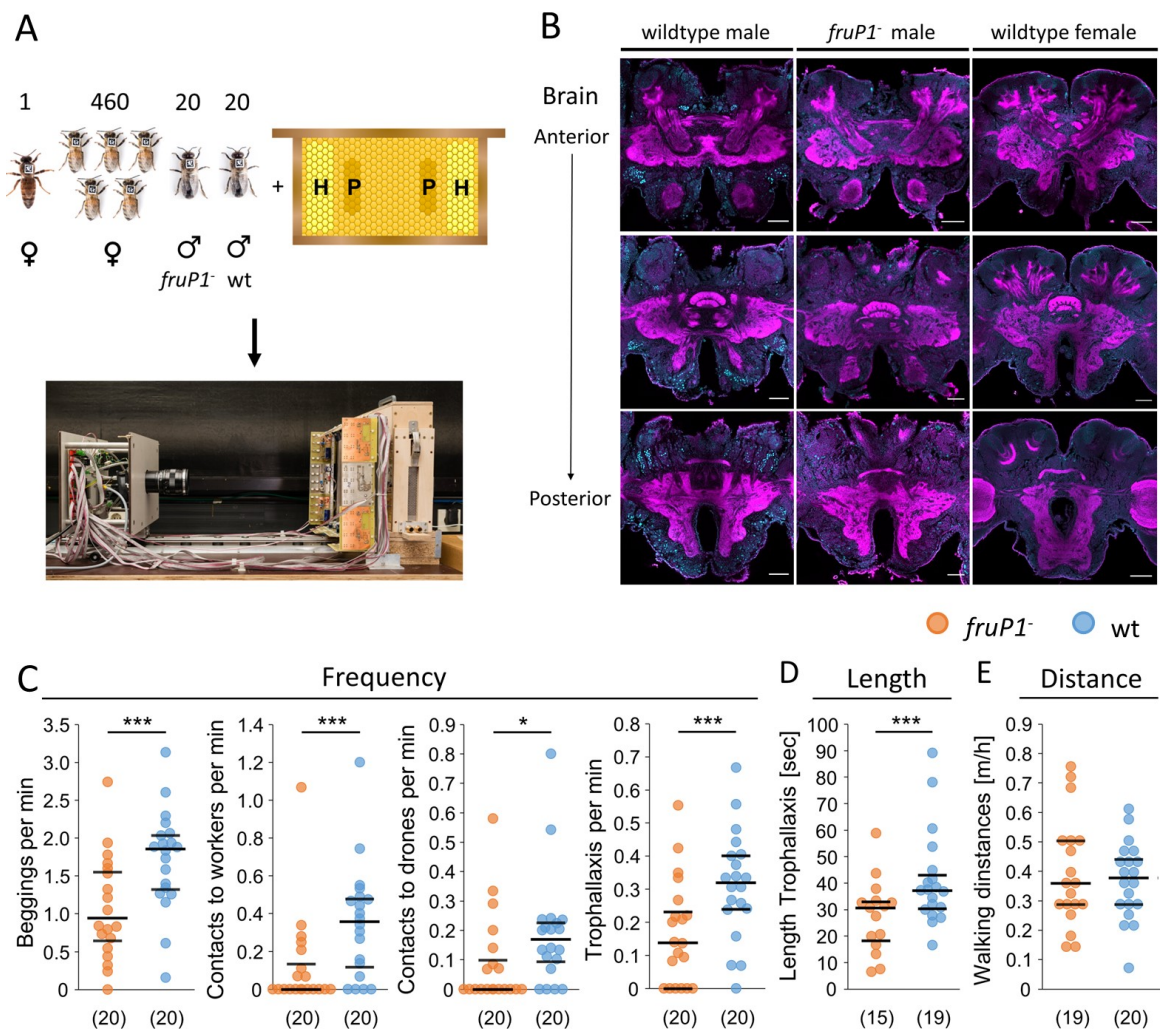

**Figure 2. *fru<sup>M</sup>* specifies group-living behaviors in male honeybees.** **A.** Behavioral examination of individual *fruP1<sup>-</sup>* and wt males in small honeybee colonies using two-dimensional barcoding and computer-based tracking. **B.** Anti-Fru immunostaining of central brains of wt and *fruP1<sup>-</sup>* male and female pupae. Magenta: Phalloidin counterstaining. Green: Anti-Fru staining. **C.** Frequency of social feeding and social contacts of *fruP1<sup>-</sup>* and wt males in the colony. **D.** Length of social feeding. **E.** Walking behaviors. Median (middle line) with quartiles Q1 and Q3 are shown. N; number of males are shown in parentheses. Min; minutes. sec; seconds. m; meters. h; hours. \* P < 0.05; \*\*\* P ≤ 0.001

However, we observed that the frequency of food begging was markedly and significantly reduced by approximately twofold in *fruP1*<sup>-</sup> compared wt males (Mann-Whitney,  $z = -2.8$ ,  $P = 0.004$ ; Fig. 2C). We found that other, rarer male contacts with workers, directed at either the abdomen or the thorax, were also reduced in *fruP1*<sup>-</sup> males (Mann-Whitney,  $z = -3.2$ ,  $P = 0.001$ ; Fig. 2C; Supplementary Videos V7-8), as were contacts with other males (Mann-Whitney,  $z = -2.4$ ,  $P = 0.015$ ; Fig. 2C; Supplementary Videos V5-6). These results suggest that the initiation of begging behavior was impaired in *fruP1*<sup>-</sup> males. For the trophallaxis behavior, we observed that the frequency was significantly reduced by more than twofold in *fruP1*<sup>-</sup> compared to wt males (Mann-Whitney,  $z = -2.7$ ,  $P = 0.005$ ; Fig. 2C). The length of this feeding behavior was significantly reduced in *fruP1*<sup>-</sup> males compared to wt males (Mann-Whitney,  $z = -2.2$ ,  $P = 0.027$ ; Fig. 2D). These results suggest that both the initiation and sustainment of the trophallaxis behavior were compromised in the *fruP1*<sup>-</sup> males. To ensure that these effects were not caused by different activity levels, we measured the walking distances and found no significant differences between *fruP1*<sup>-</sup> and wt males (Mann-Whitney,  $z = -0.9$ ,  $P = 0.94$ ; Fig. 2E). Overall, we conclude from these observations that *fru<sup>M</sup>* is required to specify aspects of the initiation of begging behavior and aspects of the initiation and maintenance of trophallaxis behavior, all behaviors central to the transfer of food from worker bees to males in the colony.

### ***fru<sup>M</sup>* transcript specifies the selection of a behavioral program in males**

The social environment of a honey bee colony is established and maintained by worker bees. Therefore, the interaction between drones and their social environment can be considered as an indirect social interaction with workers. To gain insight into whether *fru<sup>M</sup>* also specifies this type of behavior, we studied the behavior of *fruP1*<sup>-</sup> males in different areas of the combs where cells either contained pollen or honey or were empty (Supplementary Fig. S4).

We observed that *fruP1*<sup>-</sup> males regularly entered pollen-containing cells, whereas wt males essentially never did (median 0.29 versus 0 per minute; Mann-Whitney,  $z = -4.3$ ,  $P < 0.001$ ; Fig. 3A). The effects of the mutation on behavior were restricted to pollen cells. We found that the entering behavior into other cells, honey (Mann-

Whitney,  $z = 0.26$ ,  $P = 0.79$ ; Fig. 3A) and empty cells (Mann-Whitney,  $z = -0.07$ ,  $P > 0.96$  Fig. 3A) did not differ between *fruP1*<sup>-</sup> and wt males. This pollen-related behavioral impairment cannot be explained by a higher rate at which *fruP1*<sup>-</sup> males visit the pollen area and encounter pollen, since these visits were specifically reduced (Mann-Whitney,  $z = -3.1$ ,  $P = 0.002$ ; Fig. 3B). We also observed that general behaviors, self-cleaning and resting, performed in different areas of the comb were not affected (Mann-Whitney, for self-cleaning:  $z = -1.2$ ,  $P = 0.21$ ; Fig. 3C; for resting:  $z = -1.0$ ,  $P = 0.3$ ; Fig. 3D), suggesting that the impairment in *fruP1*<sup>-</sup> males is specifically associated with behaviors in the pollen stores. The action pattern of the pollen cell enterings of *fruP1*<sup>-</sup> males was consistent with the stereotypical pattern we observed for wt males in empty cells (Supplementary Videos V9 and V10). The enterings of pollen cells often occurred in short bouts of activity, a pattern which we also observed for empty cell visits in wt males (Supplementary Table S1; Supplementary Videos V11 and V12). These results indicate that it is not the sequence of the action pattern itself that is impaired in *fruP1*<sup>-</sup> males, but specifically the selection of behaviors in response to the pollen cell.

Males, younger than 4 days receive their food exclusively from workers via trophallaxis and they never feed on pollen (Free, 1957a; Wachsmann and Crailsheim, 1994). We observed that the length of cell enterings was on average 2.3 seconds, but could last more than 5 seconds (Fig. 3E), which prompted us to determine whether the *fruP1*<sup>-</sup> males feed from the pollen stores of the colony. We did not find a sizeable number of pollen grains in the midguts and hindguts of *fruP1*<sup>-</sup> males, suggesting that *fruP1*<sup>-</sup> males do not feed on pollen (Supplementary Fig. S5).

To determine whether the compromised selection of the behaviors also affected the allocation of males to different social environments, we studied the time that males spent in the different areas. We found that the *fruP1*<sup>-</sup> males spent more time in the pollen and empty areas but less time in the honey area than the wt males (Fig. 3D), suggesting that the allocations to the distinct social environment were impaired in the *fruP1*<sup>-</sup> males.

Collectively, we conclude that *fru*<sup>M</sup> is required to specify the selection of a behavioral program and the allocation with respect to distinct social environment constructed by the worker bees in a colony.

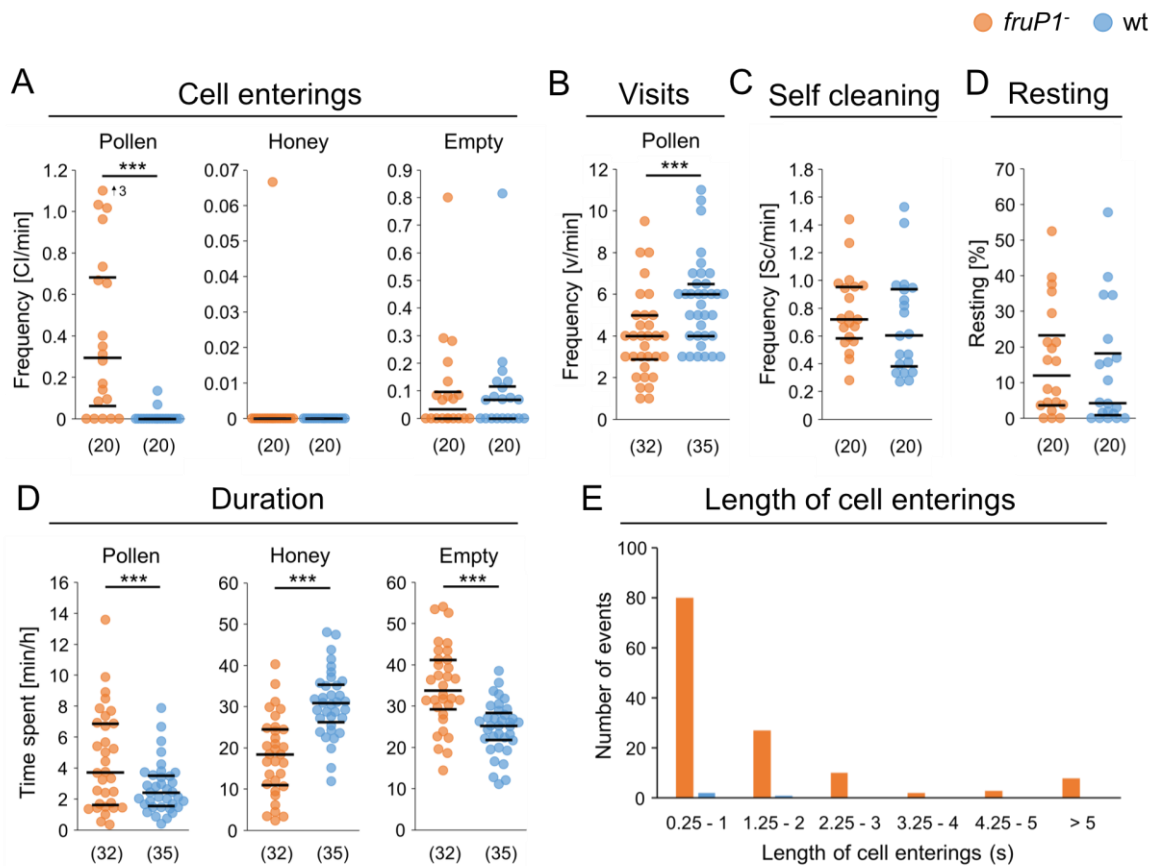

**Figure 3. *fru<sup>M</sup>* specifies the cell entering behavior and allocation on the comb** **A.** Frequency of cell enterings (CE) in pollen cells, in honey cells, and in empty cells. **B.** Frequency of pollen area visits (*v*) was increased in *fruP1<sup>-</sup>* drones. **C.** Frequency of self-cleaning behaviors (*Sc*). **D.** Proportion of time spent inactive. **D.** Differences between both groups in regard to time spent in comb areas where cells contained either pollen, honey, or were empty. **E.** Distribution of cell enterings based on their length. Median (middle line) and quartiles are shown. N values are shown in parentheses. Min: minutes, h: hours. Outliers are marked with arrows, values indicate the frequency (CE/min). \*\*\*  $P \leq 0.001$

### *fru<sup>M</sup>* is required for sexual reproduction related behaviors but not for gross sensory function

To understand whether the male-specific *fruP1* transcript also specifies reproductive behaviors, we studied the locomotion response of *fruP1<sup>-</sup>* mutant males to the sex pheromone 9-oxo-(E)-2-decenoic acid (9-ODA) in a behavioral petri dish assay. The 9-ODA pheromone is produced by queens and attracts drones during mating flights (Butler et al., 1959; Butler et al., 1962; Gary, 1962; Brockmann et al., 2006). We observed that *fruP1<sup>-</sup>* males reduced the locomotion behavior relative to *wt* males (Mann-Whitney,  $z = -2.5$ ,  $P = 0.011$ ; Fig. 4A), demonstrating that the response to the



sex pheromone 9-ODA was compromised in *fruP1*<sup>-</sup> males. We conclude that the *fru*<sup>M</sup> is required in males for the specification of behaviors related to sexual reproduction. To exclude that the behavioral malfunction of *fruP1*<sup>-</sup> males was due to impairment of general sensory functions, we quantified responses to odors, sugar, light, and the presence of two worker bees in further behavioral petri dish assays. In the control experiment, we observed that locomotion behavior of *fruP1*<sup>-</sup> males and wt males did not differ in the petri dish (Mann-Whitney,  $z = -1.0$ ,  $P = 0.298$ ; Fig. 4B). We found that locomotion response to the repellent benzaldehyde (Mann-Whitney,  $z = -0.2$ ,  $P = 0.836$ ; Fig. 4C), to light (Mann-Whitney,  $z = -0.3$ ,  $P = 0.75$ ; Fig. 4E), to honey (Fisher's exact test,  $df = 1$ ,  $P = 0.51$  supplementary Table S2), and to the presence of two worker bees (Mann-Whitney,  $z = -0.4$ ,  $P = 0.66$ ; Fig. 4D) were not different between *fruP1*<sup>-</sup> males and wt males. These results suggest that general sensory functions were not disrupted in *fruP1*<sup>-</sup> males.

To determine whether the specific behavioral defects in *fruP1*<sup>-</sup> males are associated with morphological or vitality defects, we examined anatomy and survival. We observed that the gross anatomy of the head, antennae, abdomen, legs, and the reproductive organs of *fruP1*<sup>-</sup> males did not differ from wt males (Fig. 4F). We found no differences in the survival of *fruP1*<sup>-</sup> males relative to wt males (Log-rank test,  $\text{Chi}^2 = 0.22$ ,  $df = 1$ ,  $P = 0.64$ ; Supplementary Fig. S6). Taken together, these results suggest that the specific behavioral defects cannot be explained by gross morphological or vital defects in *fruP1*<sup>-</sup> males.

The cuticular hydrocarbons (CHC) in honeybees provide important cues for social communication and recognition of colony members (Francis et al., 1989; Page et al., 1991; Wakonigg et al., 2000; van Zweden and d'Ettoire, 2010; Bastin et al., 2017). To investigate whether the *fruP1*<sup>-</sup> mutation affects the composition of CHC compounds in males, we examined the CHC profile using gas chromatography-mass spectrometry (GC/MS) analysis. We found that the detected compounds of the cuticular hydrocarbon extracts did not differ between *fruP1*<sup>-</sup> and wt males (Supplementary Fig. S7). The individual profiles of *fruP1*<sup>-</sup> and wt males, which were represented in two-dimensional MDS space, showed partial overlaps (Supplementary Fig. S8). However, we observed significant differences in the relative contribution of compounds to the CHC profiles (ANOSIM:  $R = 0.44$ ,  $p < 0.002$ ). These quantitative differences for individual compounds to the overall profiles were small and cumulative and were not associated with specific CHC classes (alkanes, alkenes, branched compounds) (Supplementary

Fig. S7). The SIMPER analysis showed that the contributions of compounds with the strongest effect on dissimilarity between profiles (that is tritriacontene (C33:1), tricosane (C23), tricosene (C23:1) and pentacosadiene (C25:2)) were only modest (6 to 7.5 %). *fruP1*<sup>-</sup> and wt males differ from the CHC profiles of workers (*fruP1*<sup>-</sup> males/workers:  $R=0.76$ ,  $p<0.001$ ; wt males/workers:  $R=0.46$ ,  $p<0.002$ ) with no overlap in the representations of two-dimensional MDS space (Supplementary Fig. S8). These results suggest that the loss of *fru*<sup>M</sup> has only slight effects on the relative abundance of the CHC compounds.

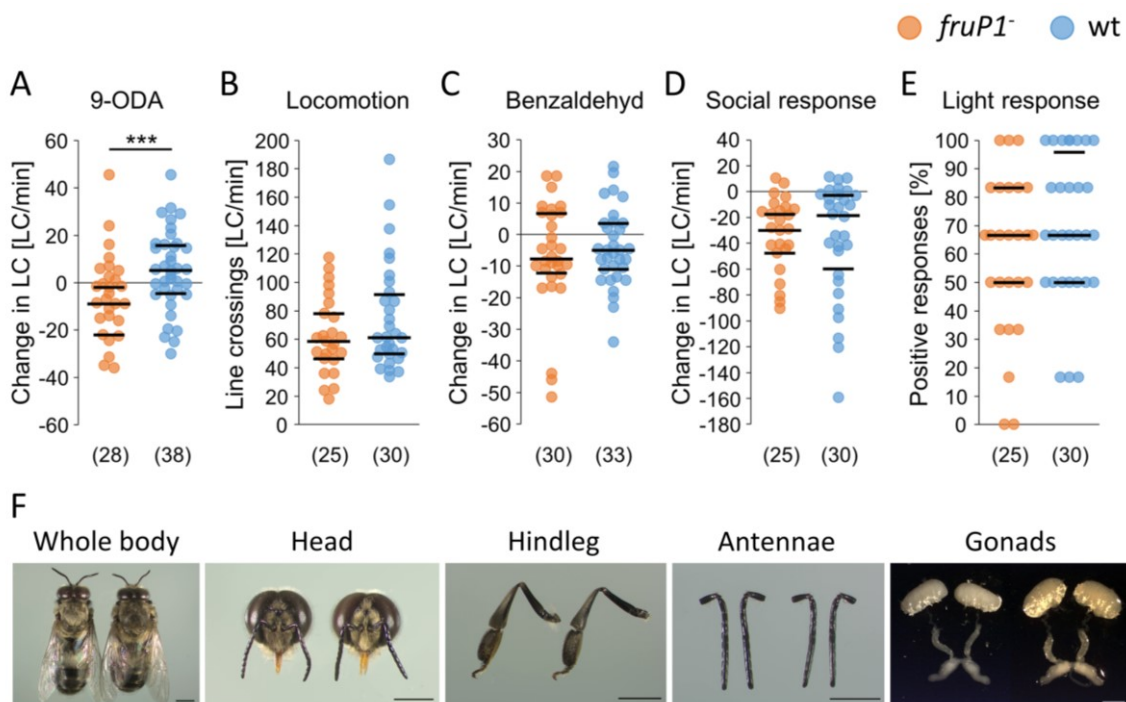

**Figure 4. *fru*<sup>M</sup> activity specifies response to 9-ODA but not general sensory functions and gross anatomy.**

*fruP1*<sup>-</sup> and wt males were tested in petri dish assays. Unless otherwise noted, individuals were at least 2 days old. **A.** Response to 9-ODA measured in line crossings (LC)/minute (min). Males analyzed were at least 5 days old. **B.** Locomotion in empty petri dish measured in LC. **C.** Repellent response of 6-day-old males measured in LC before and after addition of benzaldehyde. Both, *fruP1*<sup>-</sup> males ( $P = 0.049$ , Wilcoxon rank sum test against zero (no change)) and wt males ( $P = 0.033$ , Wilcoxon rank sum test against zero (no change)) responded to repellent by reducing the number of LC. **D.** Response to social stimuli measured in LC before and after the addition of two worker bees. Both groups responded by ceasing movement and contacting the worker bees ( $P < 0.001$ , Wilcoxon rank sum test, comparison of *fruP1*<sup>-</sup> and wt males against zero (no change)). **E.** Light response measured by males walking into a light beam. **F.** Comparison of morphology. No differences were observed for the external morphology, heads, antennae, hindlegs or gonads. Scale x mm. Median (middle line) and quartiles are shown. N values are shown in parentheses. Min: minutes. \*\*\*  $P \leq 0.001$ .

## Discussion

Social insects exhibit the most extreme form of social organization and are therefore ideal model organisms for the study of social evolution and group-living behavior (Toth and Robinson, 2007).

The gene *fruitless* and its orthologs are required for the specification of male mating behavior in the fruit fly *Drosophila melanogaster* (Demir and Dickson, 2005; Manoli et al., 2005) and in the mosquito *Aedes aegypti* (Basrur et al., 2020). Furthermore, its sex-specific splicing is conserved in many insect species, including wasps (Bertossa et al., 2009), houseflies (Meier et al., 2013), medflies (Davis et al., 2000; Salvemini et al., 2009) and mosquitoes (Gailey et al., 2006; Salvemini et al., 2013). Male honeybees, unlike males of the aforementioned species, are adapted to live in a social environment shared with nonsexual females. This evolutionary adaptation required the specification of group-living behaviors in addition to the ancestral mating behaviors. Combining a conserved gene like *fru*, which specifies aspects of male reproductive behavior, with male honeybees living in a social environment is a promising mix for understanding how group-living behaviors evolved. It has long been speculated that ancestral genetic programs for reproductive behavior may have been co-opted to regulate group-living behavior (Turillazzi and West-Eberhard, 1996; Amdam et al., 2004; Toth and Robinson, 2007). We provide evidence that the transcription factor *fru* specifies group-living behavior in male honeybees.

### ***fruitless* in the honeybee is conserved in structure, gene regulation and expression**

In *D. melanogaster*, *fru* encodes different isoforms of BTB-ZnF (BTB for broad-complex, tramtrack and bab; ZnF for zinc finger) transcription factors (Zollman et al., 1994; Ito et al., 1996; Ryner et al., 1996), and only transcripts from the most distal promoter (P1) are spliced in a sex-specific manner (Ito et al., 1996; Ryner et al., 1996; Heinrichs et al., 1998). The female-specific exon containing a stop codon, is spliced out of the male P1 transcript by a standard splicing mechanism, while the female transcript is spliced under the control of the gene *transformer* (*tra*) (Heinrichs et al., 1998). This sex-specific splicing results in either functional male-specific proteins

(FruM) containing the BTB and a ZnF domain or short female-specific proteins (FruF) lacking both domains. Transcripts from the other promoters (P2-4) are non-specific, producing common proteins (FruCOM) (Anand et al., 2001; Song et al., 2002; Dornan et al., 2005).

The structure and gene regulation of *fru* in the honeybee is very similar. As in *D. melanogaster*, *fru* encodes different isoforms, all of which contain a BTB and one of three alternative ZnF domains. Another similarity is the splicing of the P1-derived transcripts. Male splicing is the default state, whereas female splicing is controlled by the gene *feminizer* (*fem*) (Supplementary Fig. S1), an ortholog of *tra* (Hasselmann et al., 2008; Gempe et al., 2009b).

Not only gene structure and gene regulation, but also transcript and protein expression are similar between fruit flies and honeybees. We found that male-specific proteins are expressed in the brain of male honeybees but not in females (Fig. 2B), a pattern that is also found in *D. melanogaster* (Lee et al., 2000; Usui-Aoki et al., 2000). Consistent with the protein expression pattern in the brain of *D. melanogaster* males, *fru* is also expressed in clusters and in fewer individual cells, which are located in anterior and posterior areas of the male brain.

The similar structure of the gene, the same sex-specific splicing pattern under the control of *fem* and *tra*, and a similarly dispersed expression in the brain suggest that *fru* may have a function similar to that of *fru* in *D. melanogaster* and is therefore an excellent candidate for the specification of male behaviors in the honeybee. However, this conservation does not indicate an additional function, such as the specification of group-living behaviors.

### ***fru<sup>M</sup>* specifies group-living behaviors in male honeybees**

We have shown that the initiation of begging and trophallaxis behavior, as well as the sustainment of trophallaxis, is impaired in *fruP1*<sup>-</sup> drones, and that aspects of these behaviors are therefore specified by *fru<sup>M</sup>* (Fig. 2C). Both behaviors are characteristic of feeding behavior, an adaptation essential for the transition from solitary life to life in the social environment of the colony. The impairment appeared to be very specific for the initiation and sustainment of group-living behaviors, as stereotypic execution, general sensory functions (Fig. 4A-E), and behaviors that do not involve interaction

with other individuals, such as self-cleaning (Fig. 3C) or resting (Fig. 3D), remained unaffected. In addition, *fruP1*<sup>-</sup> drones initiated fewer contacts with worker bodies and with the heads of other drones (Fig. 2C). Since both behaviors can be misdirected begging attempts that can occur in young males (Ohtani, 1974), these changes could be due to impairment of the same neuronal pathway involved in begging. We conclude that *fru<sup>M</sup>* is not required for behavior in general, but very specifically for group-living behaviors.

Feeding behavior is not the only known interaction between workers and drones. It has been reported that workers can stimulate drone activity through vibration signals (Boucher and Schneider, 2009). Drones respond to these signals by increasing movement and the number of interactions with workers. The target of this behavior are sexually immature drones, so it is assumed that this is to ensure that the drones are provided with sufficient supplies to allow them to develop normally to sexual maturity.

This raises the question of how workers recognize young drones. Similarly, the fact that older drones are usually ejected from the hive earlier than young drones suggests that workers can discriminate between young and old drones (Free, 1957a; Crailsheim et al., 1999). It has been suggested that an odor-mediated mechanism enables this type of recognition and that cuticular hydrocarbon (CHC) profiles play a crucial role since they evolve with drones' age (Wakonigg et al., 2000). We found slight differences in CHC profiles (Supplementary Fig. S7), but did not observe vibration signals. However, the minor changes in CHC profiles in *fruP1*<sup>-</sup> drones cannot account for the reduced frequency of begging behavior because begging is initiated by the drones and does not depend on worker behavior. In contrast, the initiation and sustainment of trophallaxis depend on the workers' response to begging, and thus the reduced frequency of initiation and the reduced length of trophallaxis could be due to changes in CHC profiles. However, although we do not know the exact role of CHC profiles, it is likely that the reduced frequency of begging is at least partially responsible for the reduced frequency of trophallaxis behavior.

Impairment of these behaviors may also have significant implications for reproductive behavior, as nutrients provided by trophallaxis play a vital role in sexual maturation, including the development of the mucus glands, a pair of accessory glands that are part of the male reproductive tract (Mindt, 1962; Colonello and Hartfelder, 2003).

**The adaptation to the social environment built by workers is specified by *fru*<sup>M</sup>**

*fru* is not only involved in specifying group-living behaviors in terms of direct interactions with other colony members, but also in specifying behaviors that can be referred to as indirect group-living behaviors. These behaviors describe interactions with the (social) environment of the colony which is built by other group members. It is known that young drones spend more time on central combs (Free, 1957a; Stout et al., 2011) where they are fed by nurse bees, and as they get older, they move to the peripheral combs to feed themselves on honey (Free, 1957a). This adaptation involves both the specification of their allocation to specific areas of the hive and the independent feeding on honey stores. In addition, it seems reasonable that drones should remain in certain areas of the hive so as not to disturb the workers in the performance of their tasks. We found that *fruP1*<sup>-</sup> drones spent significantly more time in the pollen and empty areas and less time in the honey area compared to wt drones (Fig. 3D). The specification for the correct allocation on the comb seems to be specified by *fru* and is lost in *fruP1*<sup>-</sup> drones.

Older drones regularly enter cells in honey areas to feed (Free, 1957a). They may also repeatedly enter cells in other areas to find honey cells (Ohtani, 1974). We found that *fruP1*<sup>-</sup> males entered pollen cells more frequently than wt drones, which almost never entered (Fig. 3A). One possible explanation is that the motor neuron program for cell entry is activated in the wrong sensory context. Another hypothesis is based on the results of a recent study showing that male mosquitoes lacking male-specific *fru* expression develop a strong attraction to human odor. Attraction to human odor is a component of female-specific host-seeking behavior that eventually leads to blood feeding. This gain of female-specific behavior in males indicates that *fru* has acquired a novel role in inhibiting female host-seeking behavior in males (Basrur et al., 2020). A mechanism also found in *D. melanogaster*, where female-specific aggressive behavior in males is suppressed by *fru* (Vrontou et al., 2006).

Thus, the cell entering behavior of *fruP1*<sup>-</sup> males could accordingly represent worker behavior. Nurse bees consume large amounts of pollen to produce jelly that is fed to larvae or other adult members of the colony. This behavior consists of several steps. First finding pollen, then entering the cells, and finally feeding. However, we found no pollen grains in the guts of *fruP1*<sup>-</sup> drones, suggesting that they do not consume pollen and that only aspects of this behavior would be suppressed by *fru*.

***fru*<sup>M</sup> serves its ancestral function in specifying aspects of reproductive behavior**

Honeybee mating takes place up 10 to 40 meters in the air, where thousands of drones from up to 240 different colonies (Baudry et al., 1998) form congregations (Ruttner, 1966). Virgin queens will join the drone congregations (Ruttner and Ruttner, 1965; 1966; Koeniger and Koeniger, 2004) and copulate with 10-20 drones (Woyke, 1955; Baudry et al., 1998; Schlüns et al., 2005). However, due to the nature of honeybee mating, we were not able to examine male mating behavior itself. Instead, we analyzed the response to the queen pheromone component 9-oxo(E)-2-decenoic acid (9-ODA) (Butler et al., 1959; Butler et al., 1962) as it is known to be a sexual attractant under natural conditions (Gary, 1962; Brockmann et al., 2006) as well as in the laboratory (Brandstaetter et al., 2014). Upon presentation of 9-ODA *fruP1*<sup>-</sup> drones reduced their locomotion, while wt drones increased the number of line crossings in a petri dish assay (Fig. 4A). This significant difference in response to 9-ODA indicates that *Am-fru* is required to specify pheromone perception and thus parts of reproductive behavior. Olfactory cues also play an important role in *D. melanogaster* mating behavior. A neural circuit composed exclusively of interconnected Fru<sup>M</sup>-expressing neurons dedicated to the detection and response to a male pheromone has been identified (Ruta et al., 2010). The volatile pheromone 11-cis-vaccenyl acetate (cVA) is attractive to females and inhibitory to males (Kurtovic et al., 2007). Considering the similar expression pattern of *fru* in honeybee males, such a circuit is conceivable for 9-ODA, but would need to be demonstrated.

**How does *fru* act to specify behavior?**

We have shown that male-specific transcripts of a single gene, *fru*, specify the response to 9-ODA, suggesting involvement in reproductive behavior, and, more intriguingly, specify group-living behavior in male honeybees. This involves group-living behaviors in terms of direct interactions with workers, such as begging and trophallaxis, as well as interaction with their environment in terms of allocation to specific areas of the colony. These findings raise the question of how *fru* acts at the cellular level. Are the same neurons involved in both types of behaviors, or are there

unique neuronal anatomical and molecular features that are specifically dedicated to group-living behaviors?

For courtship behavior in *D. melanogaster*, Fru<sup>M</sup> (together with Dsx<sup>M</sup>) is known to establish sexually dimorphic or male-specific neurons in the sensory, central, and motor systems (reviewed in Yamamoto and Koganezawa, 2013). As mentioned above, even a circuit dedicated to mating behavior, consisting exclusively of interconnected Fru<sup>M</sup>- expressing neurons, has been found (Ruta et al., 2010). Analysis of the projection patterns and connections of Fru<sup>M</sup>- expressing neurons in male honeybees would clearly be the next critical step in understanding the exact mode of action of *fru<sup>M</sup>* in specifying male-specific behaviors.

## Methods

### Honeybee source

The colonies were located in the bee yard or in the containment at the Heinrich-Heine University Düsseldorf, Germany. The genetically manipulated honeybees were maintained together with worker bees in small mating nucleus hives (Segeberger nucs), which we kept in a secure containment (flight cage or laboratory) so that genetically manipulated animals could not escape into nature.

### RNAi mediated knockdown procedure

Female eggs were injected with *fem* siRNAs and larvae were reared to 5th instar (L5) as described (Gempe et al., 2009a).

### CRISPR/Cas9 experimental procedure

Target sites for the sgRNAs were identified using Benchling software (Biology Software, 2017, <https://benchling.com>), resulting in *fruP1* sgRNAs 6 (GATACCCCCACGACATTTTC) and 12 (GGCTGCTGTGCACGCTTAGA). Diploid



female eggs were collected from wt queens and injected (Schulte et al., 2014; Roth et al., 2019) with a molar ratio of Cas9 to sgRNA6 to sgRNA12 of 1:1:1. The target site of sgRNA6 is located 855 bp upstream of the designated start of the P1 transcript. The target site of sgRNA12 is positioned 232 bp downstream of the start codon (Fig. 1C). sgRNAs were generated and purified as described (Roth et al., 2019) using the RiboMax Kit (Promega, Madison, WI) and MEGAclear Kit (Ambion) following the manufacturer's instructions.

Queens were reared according to Schulte et al. (2014) and genotypes at target sites were determined via PCR amplification (see DNA preparation). Mutant queens were treated twice with CO<sub>2</sub> (on day 9 and day 10) to stimulate oviposition of unfertilized eggs which developed into males. Queens were introduced into small colonies and nucs (Holtermann, Germany).

### **Drone handling experimental procedure**

Capped male brood from *fruP1<sup>-</sup>/fruP1<sup>-</sup>* and wt queen colonies were placed in separate nucs in an incubator at 34 °C along with capped wild-type worker brood frames and a comb containing honey and pollen. *fruP1<sup>-</sup>* and wt adult males were color coded to keep track of their age. Adult workers were removed from the nucs each morning while the age of the dead drones was examined.

### **Honeybee tracking procedure and behavioral analysis in colonies**

Newly emerged (0-24 hours old) *fruP1<sup>-</sup>* males, wt males and worker bees were individually tagged with 2D barcodes. We transferred 20 *fruP1<sup>-</sup>*, 20 wt males, 460 worker bees and a queen to a standardized comb containing the same amount of honey and pollen in identical areas in each replicate (Blut, 2018; supplementary Fig. 4). Each of the two pollen areas contained 15 grams of pollen ("Echter Deutscher Spezial Blütenpollen", Werner-Seip-Biozentrum GmbH & Co. KG, Butzbach, Germany), which we fixed by adding 25 µl of sugar syrup ("Ambrosia Futtersirup", Nordzucker AG, Braunschweig, Germany) to each cell. The honey area consisted of 225 cells on both sides of the comb, each filled with 200 µl of sugar syrup. This small

colony was kept at 34 °C overnight. The next morning, the tracking was started for 24 hours at room temperature. The two colony replicates were started on August 25<sup>th</sup> (tracking 1) and on September 8<sup>th</sup> (tracking 2), respectively.

Tags were computer-based tracked using the Bee Behavioral Annotation System (BBAS; Blut et al., 2017). Bee trajectories were not continuous, and gaps resulting from single missing frames, were linearly interpolated.

To measure occupation time (minutes spent in area/hour), number of visits (visits/hour) and walking distance (meter/hour) we used C++ and Java programs scripts. The parameters were obtained for each hour of tracking. We excluded any hour in which the detection rate was less than 10%, corresponding to 6 minutes. Individuals with more than 12 hours (50%) of excluded data were not included in the analysis. Occupation time (min/h) is the total time spent by a bee in a given area, calculated as the time spent in the area between the first and last detections. The number of visits (v/h) is the number of first detections in a specific area after visiting another area. Walking distance (m/h) was the distance covered by a bee during the time it was detected. It was calculated for the hour containing the behavioral evaluation period.

To follow the behavioral repertoire of male bees in the colony, the tracking data were overlaid on the video using VirtualDub software (VirtualDub-1.9.11, virtualdub.org) (Mersch et al., 2013). This allowed us to continuously track individual tagged males throughout the observation period, even when the barcode was not automatically recognized by the computer program. Behavior of *fruP1*<sup>-</sup> males and wt males was recorded for 15 minutes between 12 am and 3.30 pm. The examinations were blinded. The investigator was unaware of whether the male being studied belonged to the control or mutant group. Individuals that rested for more than 40% of the time during the observation (an indication that these are a sleeping phase) were not included in the analysis.

Male behaviors tend to follow stereotypical patterns. They were categorized according to the study of Ohtani (1974). We defined resting as a behavior in which males did not move for at least 5 seconds, except for the minimal movements caused by respiration. If a male was disturbed by other bees and moved to a new spot, but repeated its resting behavior within 10 seconds, we considered this together as a single resting event. Self-cleaning includes two different types of cleaning. First, head cleaning, where the forelegs are used to brush the head, and second, body cleaning, where the body is brushed using the hindlegs. Cell entering behavior describes the pattern of actions

when the male enters a cell on the comb with its head. These cell enterings can occur repeatedly in different cells within short periods of 10 seconds, which we also recorded as bouts of cell entering activity (adapted from Johnson, 2008).

All of the following behaviors were initiated by the drones analyzed and do not represent a response to a contact initiated by workers or other drones. All contacts involve the use of either the antennae or the proboscis, or both. When a male contacts a worker's head with either its antennae or its proboscis, we report this behavior as begging, since it eventually leads to trophallaxis. Male contact with workers with antennae or proboscis directed toward the abdomen or thorax was reported as other contact behavior. Behaviors in which males approached and touched other males with their antennae or proboscis were reported as other male contact behaviors. Trophallaxis refers to the feeding of drones by workers. During this interaction, the drone's glossa protrudes between the worker's mandibles to suck food droplets. The forelegs tap the worker's forebody and the head rolls. The length of trophallaxis was the time between the onset of food exchange and the cessation of feeding by the worker or the cessation of accepting food by the drone. The length of a cell entering was the time the head remained in the cell.

### **Immunohistology and image processing**

We developed a specific anti-Fru protein antibody against the honeybee Fru protein. We produced a 98 amino acid long protein fragment (VSQHLLPMFLKTAELQIRGLTDNSVNNKTEEKSPSPEPETQTGIRHTESPNLQPP PEKRKRKASGSYDVSLSGPPSERFMSDSQTSSQCSYKSSPPV), which is common to all protein variants. A rabbit was immunized with the protein fragment (Seqlab, Göttingen, Germany) and the anti-Fru antibodies were purified from the serum using HiTrap NHS-activated HP columns (GE Healthcare Life Sciences, Freiburg, Germany) following the manufacturer's instructions.

For whole mounts, brains of male P2 pupae were dissected in ice-cold honeybee saline (130 mM NaCl, 5 mM KCl, 4 mM MgCl<sub>2</sub>, 5 mM CaCl<sub>2</sub>, 15 mM Hepes, 25 mM glucose, 150 mM sucrose, pH 7.2) and fixed in 4% ice-cold formaldehyde (Roth, Karlsruhe, Germany) in phosphate-buffered saline (PBS, pH 7.2) at 4°C for at least 24 hours. The brains were washed 3 x 10 minutes in PBS, 1 x 10 minutes in PBS containing 2%

Triton X-100 (PBS-T) and 2 x 10 minutes in 0.2% PBS-T. All washing steps were performed at room temperature on a shaker. Brains were blocked at room temperature for 1 hour in 0.2% PBS-T containing 2 % normal goat serum (NGS), and incubated with 0.2 units of Alexa Flour 568 phalloidin (Molecular Probes, A-12380, Eugene, USA) and rabbit-anti-Fruitless antibody (1:800) in blocking solution for 4 days at 4°C. Next the brains were washed 3 x 1 hour and incubated with goat-anti-rabbit secondary antibody (1:800; Fisher Scientific, Schwerte, Germany) in 0.2 % PBS-T with 2 % NGS for 2 days at 4 °C on shaker. After washing 4 x 5 minutes in PBS, the brains were dehydrated in an isopropanol series (10, 30, 50, 70, 90% isopropanol in PBS and 2 x 100 % isopropanol, 5 minutes each step) and subsequently cleared in methyl-salicylate (MS 99%; Sigma Aldrich, Steinheim, Germany) before mounting in fresh MS and storing at 4 °C in the dark until imaging.

For cryosections, brains of male P3 pupae were dissected in ice-cold phosphate-buffered saline (PBS, pH 7.2) and fixed in 4% ice-cold formaldehyde (Roth, Karlsruhe, Germany) in phosphate-buffered saline (PBS, pH 7.2) with 8% sucrose at room temperature (RT) for 90 minutes. Fixed brains were washed 3 x 10 minutes in PBS at RT on a shaker. They were then incubated in 10% and 20% sucrose solutions (in PBS, 30 minutes each step) and in 30% sucrose in PBS overnight at 4°C on a shaker. The next day, brains were frozen in Tissue Imbed Media on dry ice and cryosections of 10 µm or 20 µm were made. Cryosections were washed 3 x 10 minutes at RT in PBS containing 0.1 % Triton X-100 (PBS-T) and incubated with anti-Fruitless antibody (1:10000) in antibody solution (0.1 % PBS-T containing 0.1 % bovine serum albumin (BSA)) at 4 °C on a shaker overnight. After washing 3 x 10 minutes at RT in 0.1 % PBS-T, the cryosections were incubated with the secondary antibody donkey anti-rabbit Cy3 (1:200) in antibody solution at RT. After 90 minutes, the secondary antibody was replaced with antibody solution containing Hoechst34580. Cryosections were incubated for a further 30 minutes at RT, washed 3 x 10 minutes and embedded in glycerol-propyl-gallate.

Confocal images of wholemounts were captured on a Leica TSC SP8 STED 3X (Leica Microsystems, Wetzlar, Germany) at 512 x 512 pixels using a 20x objective (multi/ NA 0.75). Cryosections were imaged with a laser-scanning confocal microscope (Zeiss LSM510, Carl Zeiss Microscopy, Jena, Germany).

## DNA and RNA preparation and PCR procedures

Genomic DNA was isolated from two opposite legs with the innuPREP DNA Mini Kit (Analytik Jena, Jena, Germany).

Total RNA was isolated from whole larvae, heads, or brains using a Trizol-based protocol (Vleurinck et al., 2016). Each sample was homogenized with a pestle in 200  $\mu$ l Trizol reagent, vortexed for 30 seconds, and incubated for 5 minutes at room temperature. 50  $\mu$ l of chloroform was added to the samples, which were then vortexed for 30 seconds, and incubated at for 5 minutes at room temperature. After centrifugation for 15 minutes at 4 °C and 13,000 rpm, the upper phase was combined with an equal volume of isopropanol. The samples were then incubated for 10 minutes at room temperature and centrifuged for 10 minutes at 4°C and 13,000 rpm. The RNA pellet was washed with 250  $\mu$ l of 70 % ethanol, dried, and dissolved in 23  $\mu$ l of nuclease free water. First-strand cDNA was synthesized using the RevertAid First Strand cDNA Synthesis Kit (Thermo Scientific).

For expression analysis of different *fru* transcripts, cDNA was amplified by PCR using Taq polymerase (isolated from our laboratory strain of *Escherichia coli*) and oligonucleotide primers SK60/SK61 for female P1 transcripts and SK73&SK61 for male *fru* P1 transcripts, respectively. P2 transcripts were amplified using oligonucleotide primers M72/M74, while oligonucleotides M76/M74 were used for P3 transcripts. The housekeeping gene *elongation factor 1-alpha* was used to adjust cDNA samples for the semiquantitative analysis. All amplicons were resolved by agarose gel electrophoresis.

To identify and characterize the mutants, genomic DNA of the target region was amplified by PCR (Hasselman and Beye, 2004) using Phusion High-Fidelity DNA Polymerase and oligonucleotide primers SK52 and SK32. Amplicons from three progeny of each mutant queen were cloned into pGEM-T Easy vector (Promega, Madison, WI) and at least three clones each were double-strand sequenced (Sanger sequencing; Mix2Seq Kit, Eurofins, Ebersberg, Germany).

The 5' and the 3' of the *fru* transcripts were identified by RACE experiments using mRNAs from 2-4 day old male and female pupal heads as templates (Gempe et al., 2009a) while the exon structure was determined by mapping the amplicon sequences of *fru* RT-PCRs spanning the different exons on the genomic sequence. Semiquantitative RT-RPCR amplifications were run under non-saturating conditions and

in technical triplicates for each bee sample, using *elongation factor 1 $\alpha$*  (*ef1 $\alpha$* ) as a control. The oligonucleotides used (Eurofins Genomics, Ebersberg, Germany) with their sequences are listed in Supplementary Table S3.

### **Analysis gut content**

Drones were removed from the nuc shortly after their emergence (0-24h) and introduced to another nuc containing a comb with pollen and honey for 24 hours. The midgut and hindguts of *fruP1*- and wt drones were removed and pictures were taken using a binocular (S8 APO, Leica) with an attached camera (UI-1240LE-C-HQ) and the uEye Cockpit software (IDS). The midgut and hindgut were then cut into small pieces and the contents diluted in 80 $\mu$ l H<sub>2</sub>O. 40 $\mu$ l of this suspension was put on a microslide and the number of pollen grains was counted under a microscope (Axiovert 25 CFL, Zeiss).

### **Anatomical analysis**

Images of the gross anatomy were taken using a binocular (SteREO Discovery.V12, Zeiss) with an attached camera (AxioCam 208 color, Zeiss) and 3D software (ZEN blue, Zeiss).

Reproductive organs of 1- to 2- day-old males (0-48h) were dissected and imaged using a binocular (S8 APO, Leica) with an attached camera (UI-1240LE-C-HQ, IDS Imaging Development Systems) and the uEye Cockpit software (IDS).

### **Behavioral assays**

Locomotion responses of males to light, odor, and worker bees were measured in square petri dishes of 12 cm<sup>2</sup> size (Supplementary Fig. S9) under a fume hood. Ventilation holes of 5 mm diameter were made in the center of each side of the petri dish. Males exhibiting locomotion behavior in the nucs were placed in the petri dish

and left there for 5 minutes prior to the start of the assay. Unless otherwise stated, males were 2 to 12 days old.

Responses to light were measured under red light conditions (a light not perceived by bees). One out of four LED light sources (220 lumens, 2700 K) was turned on for 10 seconds. A response to light was scored when the bee from the opposite side moved into the light beam (Supplementary Fig. S9A; modified from (Scheiner et al., 2013)). One LED light sources were placed on each sites of the petri dish, ensuring that bees were able to move from opposite site. The response of each bee was scored 6 times. General locomotion was measured in an empty arena which was placed on a paper displaying a square grid of lines (1.5 cm x 1.5 cm per grid; Supplementary Fig. S9B). Locomotion was quantified by counting the number of lines crossed by the bee within 2 minutes (Humphries et al. 2005). To score a line crossing, a male must fully cross the line with center of its thorax. Locomotion responses to odor and worker bees were quantified by calculating the differences in line crossings between control condition and treatment for each male. To quantify odor response, we introduced odor into the arena via a filter paper (75 mm, grade 413; VWR, International GmbH, Darmstadt, Germany) through a ventilation hole (Supplementary. Fig. S9D). For the 9-ODA response, we first introduced the control filter paper to which we applied 1  $\mu$ l isopropanol (the solvent of 9-ODA and the control). We replaced it with a filter paper to which we applied 1  $\mu$ l of 9-ODA (50  $\mu$ g/ $\mu$ l, dissolved in isopropanol). The filter papers were placed in the Petri dish after the isopropanol was evaporated for 1 minute. For the benzaldehyde response, the same procedure was used except that the control filter paper was not treated. 1  $\mu$ l benzaldehyde ( $\geq 99\%$ , Sigma Aldrich) was applied to the filter paper (Townsend, 1963). To quantify male locomotion in response to the presence of worker bees, the locomotion behavior of a single male was measured before and after two worker bees were introduced into the Petri dish (Supplementary Fig. S9C). Petri dishes and papers were changed after each bee was tested. We used a camera (60fps, Full HD, 44100 Hz; Casio Exilim Pro EX-F1) to count line crossings in the video recordings using VSDC Free Video Editor (Multilab LLC).

Response to honey was quantified via the proboscis extension response (PER) behavior (modified from Scheiner et al., 2013). Honey from a comb was presented to the antenna *fruP1*<sup>-</sup> and wt males that were immobilized. Males were repeatedly tested every 2 hours for a maximum of four times. If the proboscis was extended, this behavior of the male was scored as a response.

## Cuticular Hydrocarbon analysis procedures

Surface lipids were extracted from individual bees by submerging bodies in 0.5 ml of n-hexane for 1 minute. Washes were analyzed by GC/MS using a HP5890II gas chromatograph coupled to a HP5972 mass spectrometer (Hewlett Packard, Palo Alto, California, USA), equipped with a DB-5MS column (30 m, 0.25  $\mu$ m film thickness, 0.25 mm ID), with splitless injection. The GC oven was programmed from 60 to 300 °C at 10°C/ min followed by 15 min at 300 °C. Peaks were called using a standardized integration threshold in ChemStation Software (Agilent Technologies, Santa Clara, California, USA). Integrated ion currents (peak areas) of all linear and methyl-branched hydrocarbons (CHC) were used for downstream analysis.

## Statistical analysis

Statistical analysis of behavioural experiments was performed using Systat 13 and SPSS Statistics 29 Software. The Mann-Whitney U-test was used for pairwise comparisons, and the one-sample Wilcoxon (non-parametric) test was used for comparisons against zero. The log-rank test was used for pairwise comparisons of survival curves.

The compositional similarity of CHC profiles of individual bees was visualized by non-metric multidimensional scaling (n-MDS) and analyzed using one-way analysis of similarities (ANOSIM, with pairwise tests) using Primer v.6 software (Clarke, 1993; Clarke and Gorley, 2001). ANOSIM is a non-parametric permutation statistic that tests whether a factor affects the rank order of pairwise similarities in a similarity matrix (here Bray–Curtis similarities of CHC composition between individual bees). The resulting R value ( $-1 < R < 1$ ) indicates the degree of separation between treatments (complete separation:  $R = 1$ , no separation:  $R = 0$ ). To identify compounds that contributed most strongly to overall dissimilarity between treatment groups we used the SIMPER modul, also in Primer v.6. n-MDS, ANOSIM and PRIMER analyses were based on standardized (percentage), square root transformed GC/MS integrated ion currents (peak areas).



## Supplementary data

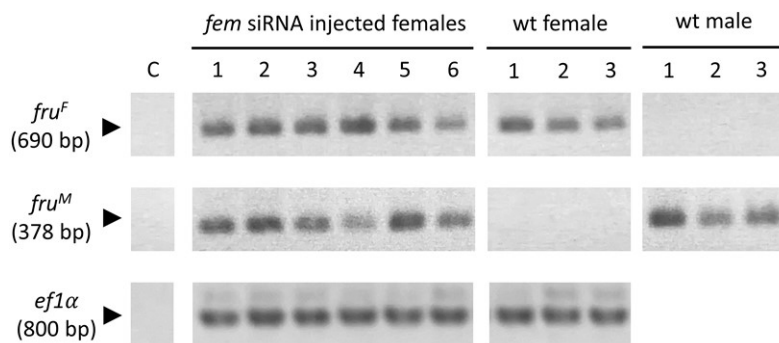

	Number of individuals		
	<i>fem</i> siRNA females	wt females	wt males
<i>Am-fru<sup>M</sup></i>	3	0	5
<i>Am-fru<sup>F</sup></i>	0	5	0
<i>Am-fru<sup>M</sup> + Am-fru<sup>F</sup></i>	12	0	0
total	15	5	5

**Figure S1.** Sex-specific splicing of *fru* transcripts in response to RNAi-mediated knockdown of the *feminizer* (*fem*) gene. Individual brains of stage 4 larvae were analyzed. Female-specific (*fru<sup>F</sup>*) and male-specific (*fru<sup>M</sup>*) *fru* fragments were amplified by RT-PCR and size resolved. PCRs were semi-quantitatively adjusted using the *ef1α* gene as a control. Table: Number of individuals in which *fru* transcripts were analyzed. Both transcripts were found in 12 injected individuals. However, only three individuals showed a complete switch to male splicing. Wt: Wildtype controls. C: Negative control for PCR.

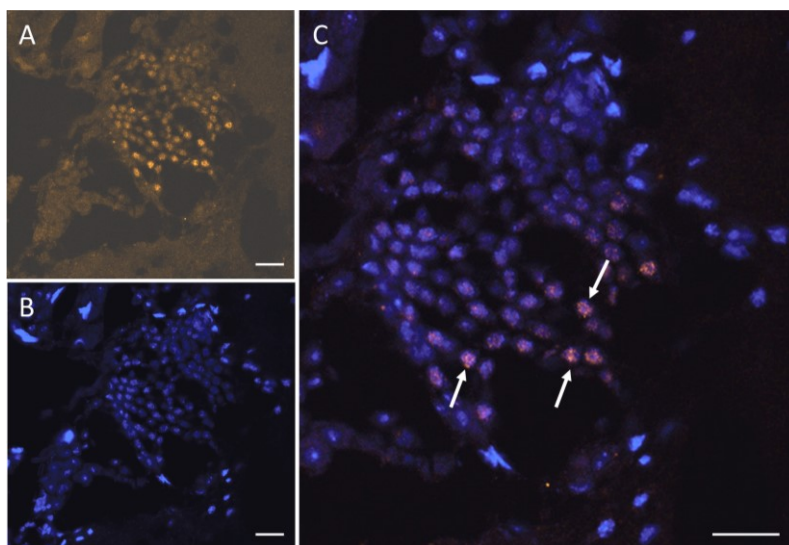

**Figure S2.** Cryosection of pupal brain (stage P3). Neuronal cluster in the midbrain (near the antennal lobes) was stained with anti-Fru antibody (A) and Hoechst34580 (nuclei staining, B). Overlay of both channels in C demonstrates Fru expression in cell nuclei. Arrows indicate examples of colocalization. Scale 20 μm.

	sgRNA6	sgRNA12
Wildtype	CTCGCAACCCCCCCTCGATACCCCCCACGACATTTCGGCCAGCC	GGCTGGCTGTGCACGCTTAGAGGGGAGGATACGGCCCTATTCTGCAG
Queen 11	.....T.....	.....
Queen 18	.....T.....GC	.....
Queen 21	.....T.....C	.....
Queen 37	.....T.....	.....

**Figure S3.** Genotype of *fruP1*/*fruP1* mutant queens. Double-strand break at both sgRNA target sites (sgRNA6 and sgRNA12) induced a deletion. Wildtype sequence for reference.

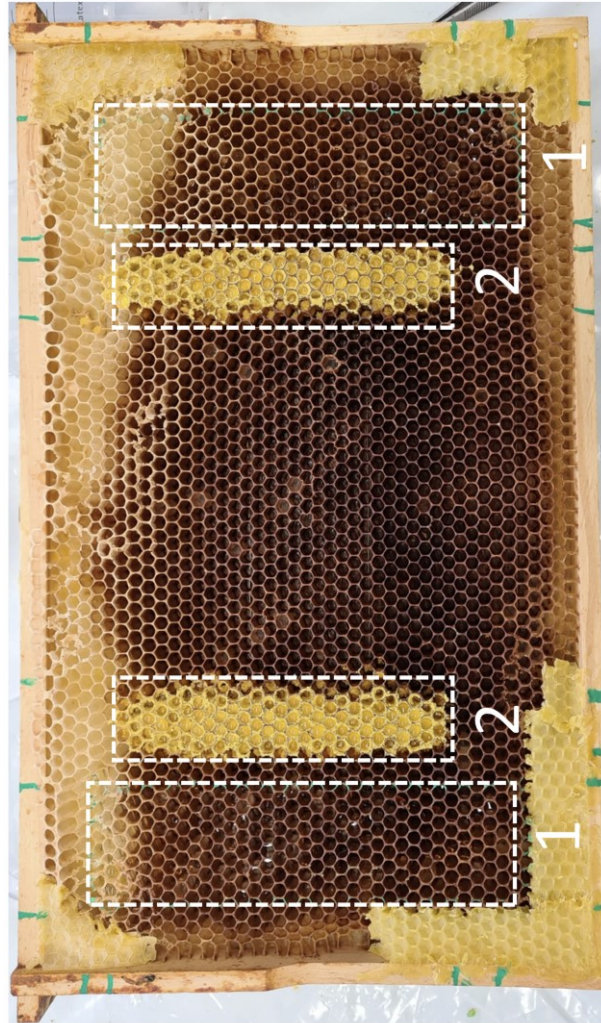

**Figure S4.** Standardized comb with honey (1) and pollen (2) areas. Honey and pollen are provided in two areas of the same size. Each honey area consists of 225 cells filled with 200 µl sugar solution. Each pollen area is filled with 15 g of grinded pollen.

**Table S1.** Number of bouts of in pollen and other (honey and empty) areas. Bouts are sequences of at least two CI's with an interval of less than 10 seconds between them.

Genotype	Number of bouts in	
	pollen area	other areas
<i>fruP1</i> <sup>-</sup>	30	5
wt	1	2

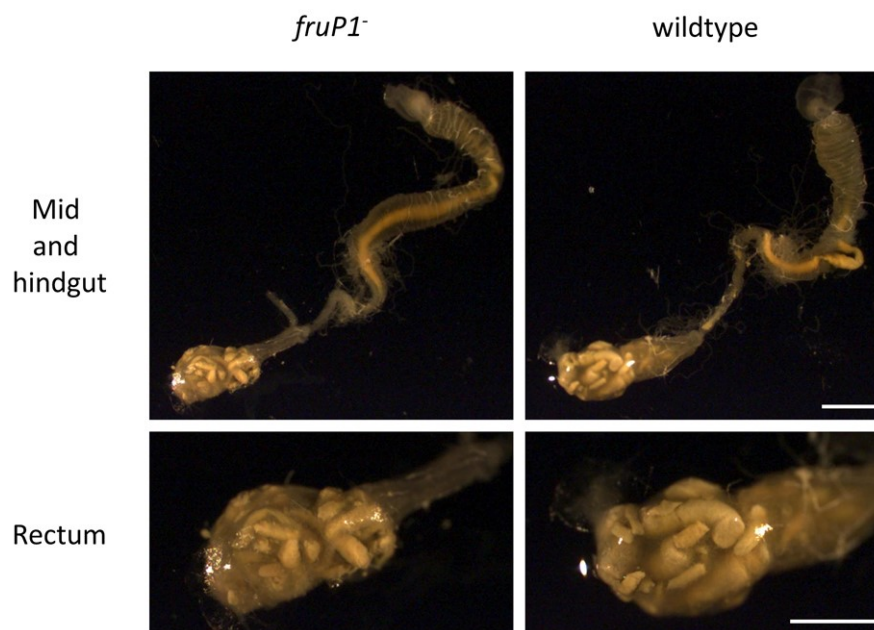

Genotype	No. of analyzed guts	No. guts containing pollen grains
<i>fruP1</i> <sup>-</sup>	8	0
wt	7	0

**Figure S5.** Midgut and hindgut dissected from adult males (1-2 days old). Midgut and hindgut contents of *fruP1*<sup>-</sup> and wt males were analyzed after being left on a comb containing pollen and honey for 24 h. Table: Number of individuals analyzed. No pollen grains were found in any of the dissected guts. Scale bar = 2 mm

**Table S2.** Fishers exact test proboscis extension response (PER). Fishers exact test statistic value is 0.51.

	Total number	PER response	PER no response
<i>fruP1</i> <sup>-</sup>	20	14 (70%)	6 (30%)
wt	20	11 (55%)	9 (45%)

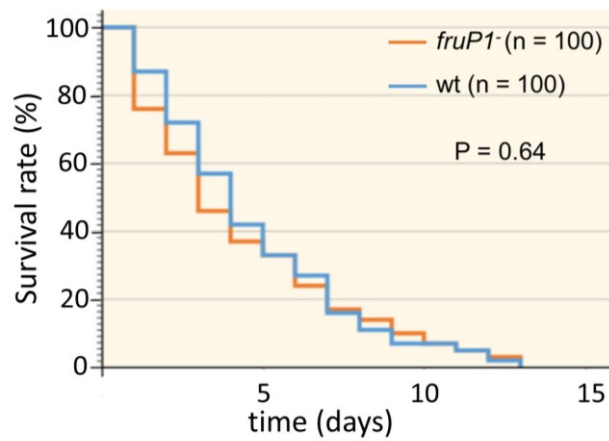
**Figure S6.** Survival curve of *fruP1*<sup>-</sup> and wt control drones which were kept in the laboratory. P value from log-rank test is indicated in the plot.

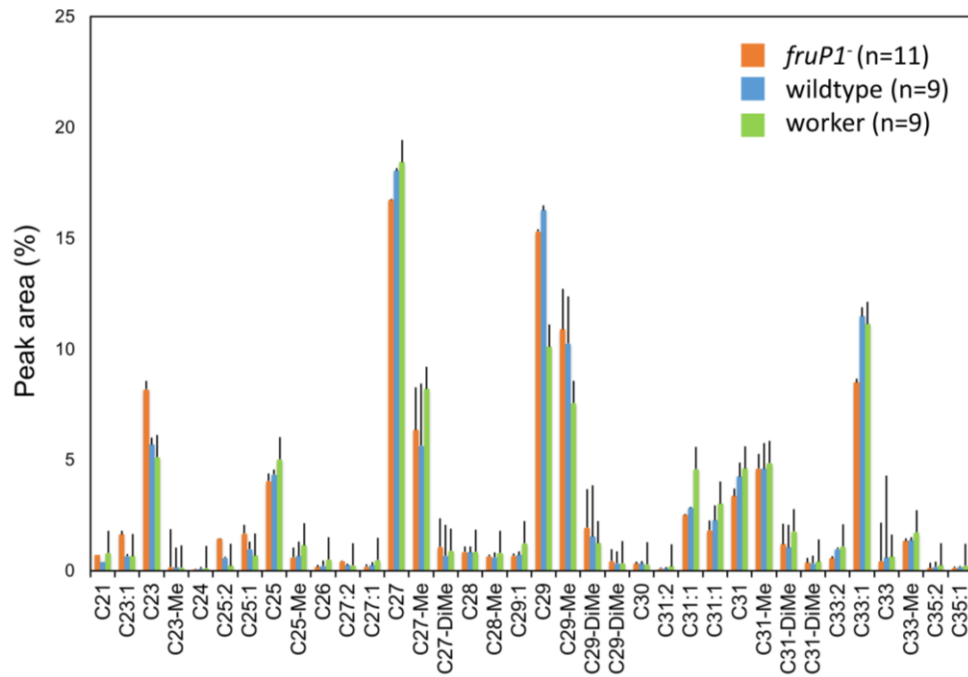

**Figure S7.** Relative abundance (integrated ion currents; GC-MS) of cuticular hydrocarbons (CHC) in hexane washes of honeybees listed by retention time on DB-5ms capillary column.

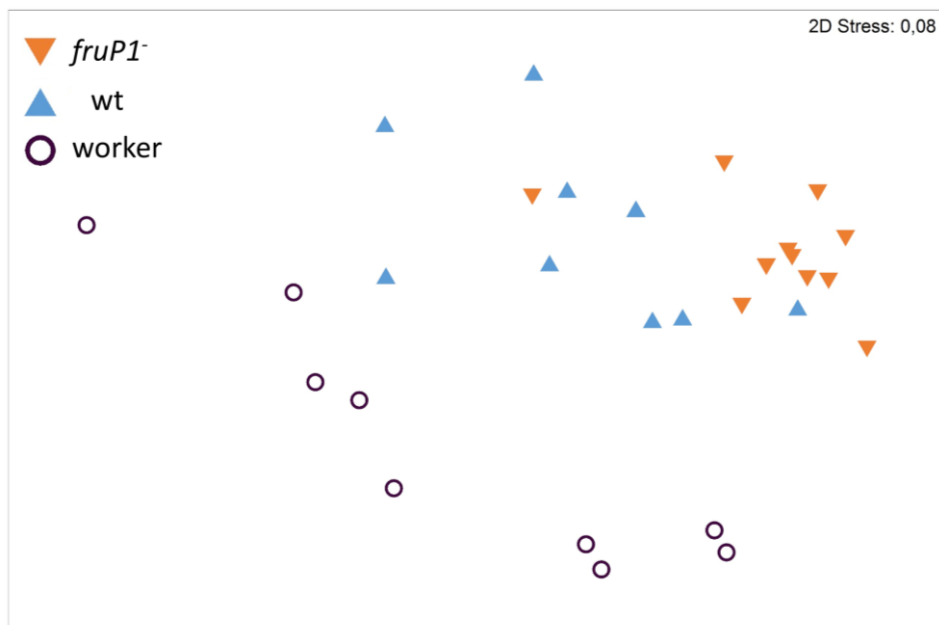

**Figure S8.** Two-dimensional Multidimensional Scaling (MDS) plot based on standardized, square-root transformed Bray-Curtis distances among cuticular hydrocarbon (CHC) profiles of wt and *fruP1*<sup>-</sup> males in comparison to workers of *Apis mellifera*. Stress of 0.08 indicates a good representation of the underlying dissimilarity matrix.

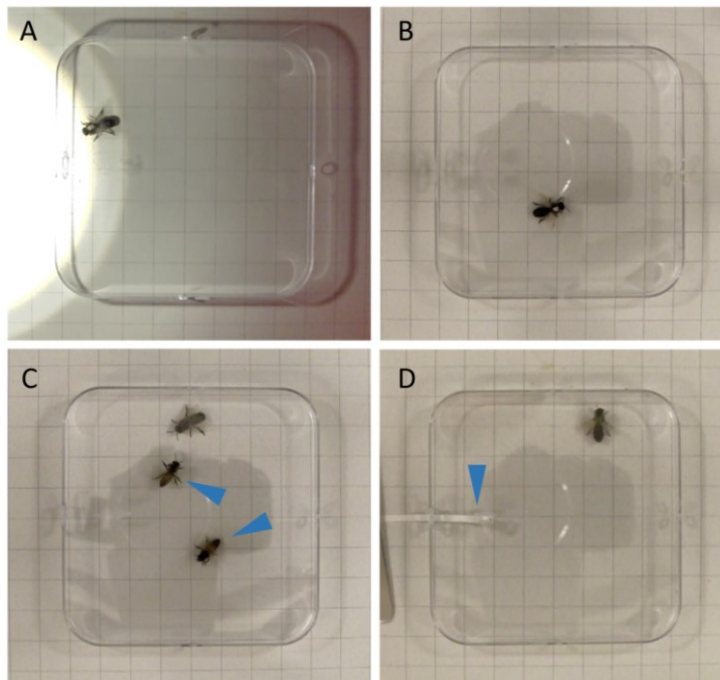

**Figure S9.** Locomotion responses in petri dishes behavioral assays. Pictures of the experimental setup showing square petri dishes with bees and the paper with lines arranged in a grid. **A.** Light response assay. **B.** Measurements of locomotion without treatment. **C.** Responses to worker bees (indicated by blue arrowheads) **D.** Responses to odor provided by the inserted filter paper (arrowhead).

**Table S3.** Nucleotide sequences of the used primers.

Name	Sequence (5' to 3')
SK52	TTACACGGCAAGCCGTGACGAG
SK32	CCATCTGAAACAATGGAACCG
SK60	AACTGATCCTCCTCCGTGCTGCG
SK61	AGTGGTTCCTGATGTGCGTCACGA
SK73	TCGCGATGCTACGTCAACTGTAGG
M72	GACGTTAAGGGTCGGGTGGC
M74	GCTGTGATGCAGGAGACATAGGTC
M76	CGGCACGTATAGTAGCGACGC
ef	GATATCGCCCTGTGGAAGTTC
ef	GCTGCTGGAGCGAATGTTAC

**Table S4.** The different behaviors studied with video examples.

Male behavior	Video		Description
	<i>fruPI</i> <sup>-</sup>	wt	
Food begging to worker	V1	V2	The highlighted male bee with the ID 18 ( <i>fruPI</i> <sup>-</sup> ) / ID 47 (wt) approaches the head of a worker bee with its antennae while extending the proboscis.
Trophallaxis with worker	V3	V4	The highlighted male bee with the ID 44 ( <i>fruPI</i> <sup>-</sup> ) / ID 16 (wt) is being fed by the worker bee. Glossa of the worker is protruded between mandibles. Forelegs of the males are occasionally patting the worker's forebody (Ohtani, 1974)
Contact drones	V5	V6	The highlighted male bee with the ID 48 ( <i>fruPI</i> <sup>-</sup> ) / ID 18 (wt) approaches the head of another drone with its antennae while extending the proboscis.
Other contact worker	V7	V8	The highlighted male bee with the ID 27 ( <i>fruPI</i> <sup>-</sup> ) / ID 50 (wt) approaches the abdomen of a worker bee with its antennae proboscis
Enter cell	V9	V10	The highlighted male bee with the ID 8 ( <i>fruPI</i> <sup>-</sup> ) / ID 33 (wt) shortly enters a cell
Bouts of cell enterings in pollen area	V11	-	The highlighted male bee with the ID 26 ( <i>fruPI</i> <sup>-</sup> ) repeatedly enters cells containing pollen in short time intervals
Bouts of cell Enterings in empty area		V12	The highlighted male bee with the ID 2 (wt) repeatedly enters empty cells in short time intervals
Self cleaning – head	V13	V14	The highlighted male bee with the ID 32 ( <i>fruPI</i> <sup>-</sup> ) / ID 44 (wt) brushes its head parts with foreleg.
Self cleaning – body	V15	V16	The highlighted male bee with the ID 40 ( <i>fruPI</i> <sup>-</sup> ) / ID 11 (wt) brushes its body with hind legs.
Resting	V17	V18	The highlighted bee with the ID 25 ( <i>fruPI</i> <sup>-</sup> ) / ID 22 (wt) rests. Antennae lowered and wings folded.

## References

- Albers, H.E. (2012). The regulation of social recognition, social communication and aggression: vasopressin in the social behavior neural network. *Horm Behav*, 61, 283-292.
- Amdam, G.V., Norberg, K., Fondrk, M.K., and Page, R.E. (2004). Reproductive ground plan may mediate colony-level selection effects on individual foraging behavior in honey bees. *Proceedings of the National Academy of Sciences of the United States of America*, 101, 11350-11355.
- Anand, A., Vilella, A., Ryner, L.C., Carlo, T., Goodwin, S.F., Song, H.J., Gailey, D.A., Morales, A., Hall, J.C., Baker, B.S., and Taylor, B.J. (2001). Molecular genetic dissection of the sex-specific and vital functions of the *Drosophila melanogaster* sex determination gene fruitless. *Genetics*, 158, 1569.
- Auer, T., and Benton, R. (2016). Sexual circuitry in *Drosophila*. *Current Opinion in Neurobiology*, 38, 18-26.
- Avargues-Weber, A., d'Amato, D., Metzler, M., Finke, V., Baracchi, D., and Dyer, A.G. (2018). Does Holistic Processing Require a Large Brain? Insights From Honeybees and Wasps in Fine Visual Recognition Tasks. *Front Psychol*, 9, 1313.
- Basrur, N.S., De Obaldia, M.E., Morita, T., Herre, M., von Heynitz, R.K., Tsitohay, Y.N., and Vosshall, L.B. (2020). Fruitless mutant male mosquitoes gain attraction to human odor. *Elife*, 9, e63982.
- Bastin, F., Savarit, F., Lafon, G., and Sandoz, J.-C. (2017). Age-specific olfactory attraction between Western honey bee drones (*Apis mellifera*) and its chemical basis. *PLOS ONE*, 12, e0185949.
- Baudry, E., Solignac, M., Garnery, L., Gries, M., Cornuet, J.M., and Koeniger, N. (1998). Relatedness among honeybees (*Apis mellifera*) of a drone congregation. *Proceedings of the Royal Society B: Biological Sciences*, 265, 2009.
- Benson-Amram, S., Dantzer, B., Stricker, G., Swanson, E.M., and Holekamp, K.E. (2016). Brain size predicts problem-solving ability in mammalian carnivores. *Proc Natl Acad Sci U S A*, 113, 2532-2537.
- Bertossa, R.C., van de Zande, L., and Beukeboom, L.W. (2009). The Fruitless gene in *Nasonia* displays complex sex-specific splicing and contains new zinc finger domains. *Mol Biol Evol*, 26, 1557-1569.
- Beye, M., Hasselmann, M., Fondrk, M.K., Page, R.E., and Omholt, S.W. (2003). The gene *csd* is the primary signal for sexual development in the honeybee and encodes an SR-type protein. *Cell*, 114, 419-429.
- Beye, M., Hunt, G.J., Page, R.E., Kim Fondrk, M., Grohmann, L., and Moritz, R.F.A. (1999). Unusually high recombination rate detected in the sex locus region of the honey bee (*Apis mellifera*). *Genetics*, 153, 1701-1708.
- Billeter, J.-C., Atallah, J., Krupp, J.J., Millar, J.G., and Levine, J.D. (2009). Specialized cells tag sexual and species identity in *Drosophila melanogaster*. *Nature*, 461, 987-991.
- Blut, C. (2018). An innovative computer-based method for continuous behavioural detection in honeybee colonies (*Apis mellifera*) and the social organization of moving behaviour on the comb. (Universitäts- und Landesbibliothek der Heinrich-Heine-Universität Düsseldorf).



- Blut, C., Crespi, A., Mersch, D., Keller, L., Zhao, L., Kollmann, M., Schellscheidt, B., Fülber, C., and Beye, M. (2017). Automated computer-based detection of encounter behaviours in groups of honeybees. *Scientific reports*, 7, 17663.
- Boucher, M., and Schneider, S.S. (2009). Communication signals used in worker–drone interactions in the honeybee, *Apis mellifera*. *Animal Behaviour*, 78, 247-254.
- Brandstaetter, A.S., Bastin, F., and Sandoz, J.C. (2014). Honeybee drones are attracted by groups of consexuales in a walking simulator. *Journal of Experimental Biology*, 217, 1278-1285.
- Brockmann, A., Dietz, D., Spaethe, J., and Tautz, J. (2006). Beyond 9-ODA: sex pheromone communication in the European honey bee *Apis mellifera* L. *Journal of chemical ecology*, 32, 657-667.
- Butler, B., Pirrotta, V., Irminger-Finger, I., and Nothiger, R. (1986). The sex-determining gene tra of *Drosophila*: molecular cloning and transformation studies. *EMBO J.*, 5, 3607-3613.
- Butler, C.G., Callow, R.K., and Johnston, N.C. (1959). Extraction and Purification of 'Queen Substance' from Queen Bees. *Nature* 1959 184:4702, 184, 1871-1871.
- Butler, C.G., Callow, R.K., Johnston, N.C., Butler, C.G., Callow, R.K., and Johnston, N.C. (1962). The Isolation and Synthesis of Queen Substance, 9-oxodec-trans-2-enoic Acid, a Honeybee Pheromone. *RSPSB*, 155, 417-432.
- Carcaud, J., Giurfa, M., and Sandoz, J.C. (2015). Differential combinatorial coding of pheromones in two olfactory subsystems of the honey bee brain. *J Neurosci*, 35, 4157-4167.
- Clarke, K., and Gorley, R. (2001). Primer V5: User Manual/Tutorial. PRIMER-E Ltd.; Plymouth, 91.
- Clarke, K.R. (1993). Non-parametric multivariate analyses of changes in community structure. *Australian journal of ecology*, 18, 117-143.
- Colonello, N.A., and Hartfelder, K. (2003). Protein content and pattern during mucus gland maturation and its ecdysteroid control in honey bee drones. *Apidologie*, 34, 257-267.
- Crailsheim, K., Eggenreich, U., Ressi, R., and Szolderits, M.J. (1999). Temperature Preference of Honeybee Drones (Hymenoptera: Apidae). *Entomologia Generalis*, 24, 37-47.
- Davis, T., Kurihara, J., Yoshino, E., and Yamamoto, D. (2000). Genomic Organisation of the Neural Sex Determination Gene Fruitless (*Fuu*) in the Hawaiian Species *Drosophila silvestris* and the Conservation of the Fru BTB Protein-Protein-Binding Domain Throughout Evolution\*. *Hereditas*, 132, 67-78.
- Demir, E., and Dickson, B.J. (2005). fruitless Splicing Specifies Male Courtship Behavior in *Drosophila*. *Cell*, 121, 785-794.
- Dornan, A.J., Gailey, D.A., and Goodwin, S.F. (2005). GAL4 enhancer trap targeting of the *Drosophila* sex determination gene fruitless. *Genesis (New York, N.Y. : 2000)*, 42, 236-246.
- Dunbar, R.I. (2009). The social brain hypothesis and its implications for social evolution. *Ann Hum Biol*, 36, 562-572.
- Enard, W., Gehre, S., Hammerschmidt, K., Holter, S.M., Blass, T., Somel, M., Bruckner, M.K., Schreiweis, C., Winter, C., Sohr, R., et al. (2009). A humanized version of *Foxp2* affects cortico-basal ganglia circuits in mice. *Cell*, 137, 961-971.
- Francis, B.R., Blanton, W.E., Littlefield, J.L., and Nunamaker, R.A. (1989). Hydrocarbons of the Cuticle and Hemolymph of the Adult Honey Bee

- (Hymenoptera: Apidae). *Annals of the Entomological Society of America*, 82, 486-494.
- Free, J.B. (1957a). The food of adult drone honeybees (*Apis mellifera*). *The British Journal of Animal Behaviour*, 5, 7-11.
- Free, J.B. (1957b). The transmission of food between worker honeybees. *Br J Anim Behav*, 5, 41-47.
- Gailey, D.A., Billeter, J.C., Liu, J.H., Bauzon, F., Allendorfer, J.B., and Goodwin, S.F. (2006). Functional conservation of the fruitless male sex-determination gene across 250 Myr of insect evolution. *Molecular Biology and Evolution*, 23, 633-643.
- Gary, N.E. (1962). Chemical Mating Attractants in the Queen Honey Bee. *Science (New York, N.Y.)*, 136, 773-774.
- Gempe, T., Hasselmann, M., Schiott, M., Hause, G., Otte, M., and Beye, M. (2009a). Sex determination in honeybees: two separate mechanisms induce and maintain the female pathway. *PLoS Biol*, 7, e1000222.
- Gempe, T., Hasselmann, M., Schiøtt, M., Hause, G., Otte, M., and Beye, M. (2009b). Sex determination in honeybees: two separate mechanisms induce and maintain the female pathway. *PLoS biology*, 7, e1000222.
- Gernat, T., Rao, V.D., Middendorf, M., Dankowicz, H., Goldenfeld, N., and Robinson, G.E. (2018). Automated monitoring of behavior reveals bursty interaction patterns and rapid spreading dynamics in honeybee social networks. *Proc Natl Acad Sci U S A*, 115, 1433-1438.
- Godfrey, R.K., and Gronenberg, W. (2019). Brain evolution in social insects: advocating for the comparative approach. *J Comp Physiol A Neuroethol Sens Neural Behav Physiol*, 205, 13-32.
- Groszer, M., Keays, D.A., Deacon, R.M., de Bono, J.P., Prasad-Mulcare, S., Gaub, S., Baum, M.G., French, C.A., Nicod, J., Coventry, J.A., et al. (2008). Impaired synaptic plasticity and motor learning in mice with a point mutation implicated in human speech deficits. *Curr Biol*, 18, 354-362.
- Hasselmann, M., and Beye, M. (2004). Signatures of selection among sex-determining alleles of the honey bee. *Proceedings of the National Academy of Sciences of the United States of America*, 101, 4888-4893.
- Hasselmann, M., Gempe, T., Schiott, M., Nunes-Silva, C.G., Otte, M., and Beye, M. (2008). Evidence for the evolutionary nascence of a novel sex determination pathway in honeybees. *Nature*, 454, 519-522.
- Heinrichs, V., Ryner, L.C., and Baker, B.S. (1998). Regulation of sex-specific selection of fruitless 5' splice sites by transformer and transformer-2. *Molecular and cellular biology*, 18, 450-458.
- Heyes, C. (2012). What's social about social learning? *J Comp Psychol*, 126, 193-202.
- Ito, H., Fujitani, K., Usui, K., Shimizu-Nishikawa, K., Tanaka, S., and Yamamoto, D. (1996). Sexual orientation in *Drosophila* is altered by the satori mutation in the sex-determination gene fruitless that encodes a zinc finger protein with a BTB domain. *Proceedings of the National Academy of Sciences of the United States of America*, 93, 9687.
- Jinek, M., Chylinski, K., Fonfara, I., Hauer, M., Doudna, J.A., and Charpentier, E. (2012). A programmable dual-RNA-guided DNA endonuclease in adaptive bacterial immunity. *Science (New York, N.Y.)*, 337, 816-821.
- Johnson, B.R. (2008). Within-nest temporal polyethism in the honey bee. *Behavioral Ecology and Sociobiology*, 62, 777-784.

- Kamhi, J.F., Ilies, I., and Traniello, J.F.A. (2019). Social Complexity and Brain Evolution: Comparative Analysis of Modularity and Integration in Ant Brain Organization. *Brain Behav Evol*, 93, 4-18.
- Kimura, K., Hachiya, T., Koganezawa, M., Tazawa, T., and Yamamoto, D. (2008). Fruitless and doublesex coordinate to generate male-specific neurons that can initiate courtship. *Neuron*, 59, 759-769.
- Kimura, K.I., Ote, M., Tazawa, T., and Yamamoto, D. (2005). Fruitless specifies sexually dimorphic neural circuitry in the Drosophila brain. *Nature*, 438, 229-233.
- Koeniger, N., and Koeniger, G. (2004). Mating behavior in honey bees (Apis). *Tropical Agricultural Research and Extension*, 7, 13-28.
- Kohatsu, S., and Yamamoto, D. (2015). Visually induced initiation of Drosophila innate courtship-like following pursuit is mediated by central excitatory state. *Nature Communications*, 6, 6457.
- Kurtovic, A., Widmer, A., and Dickson, B.J. (2007). A single class of olfactory neurons mediates behavioural responses to a Drosophila sex pheromone. *Nature*, 446, 542-546.
- Lee, G., Foss, M., Goodwin, S.F., Carlo, T., Taylor, B.J., and Hall, J.C. (2000). Spatial, Temporal, and Sexually Dimorphic Expression Patterns of the fruitless Gene in the Drosophila Central Nervous System. *J Neurobiol*, 43, 404-426.
- Lihoreau, M., Latty, T., and Chittka, L. (2012). An exploration of the social brain hypothesis in insects. *Frontiers in Physiology*, 3, 442.
- Manoli, D.S., Foss, M., Villella, A., Taylor, B.J., Hall, J.C., and Baker, B.S. (2005). Male-specific fruitless specifies the neural substrates of Drosophila courtship behaviour. *Nature*, 436, 395-400.
- McKeown, M., Belote, J.M., and Baker, B.S. (1987). A molecular analysis of transformer, a gene in Drosophila melanogaster that controls female sexual differentiation. *Cell*, 48, 489-499.
- Medvedeva, V.P., Rieger, M.A., Vieth, B., Mombereau, C., Ziegenhain, C., Ghosh, T., Cressant, A., Enard, W., Granon, S., Dougherty, J.D., and Groszer, M. (2019). Altered social behavior in mice carrying a cortical Foxp2 deletion. *Human Molecular Genetics*, 28, 701-717.
- Meier, N., Kappeli, S.C., Hediger Niessen, M., Billeter, J.C., Goodwin, S.F., and Bopp, D. (2013). Genetic control of courtship behavior in the housefly: evidence for a conserved bifurcation of the sex-determining pathway. *PLoS One*, 8, e62476.
- Mersch, D.P., Crespi, A., and Keller, L. (2013). Tracking individuals shows spatial fidelity is a key regulator of ant social organization. *Science (New York, N.Y.)*, 340, 1090-1093.
- Mindt, B. (1962). Untersuchungen über das Leben der Drohnen, insbesondere Ernährung und Geschlechtsreife. *Z. Bienenforsch.*, 6, 9-33.
- Netschitailo, O., Wang, Y., Wagner, A., Sommer, V., Verhulst, E.C., and Beye, M. (2023). The function and evolution of a genetic switch controlling sexually dimorphic eye differentiation in honeybees. *Nat Commun*, 14, 463.
- Ohtani, T. (1974). Behavior Repertoire of Adult Drone Honeybee within Observation Hives. *Jour. Fac. Sci. Hokkaido Univ. Ser. VI, Zool*, 19, 706-721.
- Page, R.E., Metcalf, R.A., Metcalf, R.L., Erickson, E.H., and Lampman, R.L. (1991). Extractable hydrocarbons and kin recognition in honeybee (Apis mellifera L.). *Journal of chemical ecology*, 17, 745-756.

- Palmateer, C.M., Artikis, C., Brovero, S.G., Friedman, B., Gresham, A., and Arbeitman, M.N. (2023). Single-cell transcriptome profiles of *Drosophila* fruitless-expressing neurons from both sexes. *Elife*, 12, e78511.
- Pane, A., Salvemini, M., Bovi, P.D., Polito, C., and Saccone, G. (2002). The transformer gene in *Ceratitidis capitata* provides a genetic basis for selecting and remembering the sexual fate. *Development*, 129, 3715-3725.
- Reimers-Kipping, S., Hevers, W., Paabo, S., and Enard, W. (2011). Humanized Foxp2 specifically affects cortico-basal ganglia circuits. *Neuroscience*, 175, 75-84.
- Ribeiro, I.M.A., Drews, M., Bahl, A., Machacek, C., Borst, A., and Dickson, B.J. (2018). Visual Projection Neurons Mediating Directed Courtship in *Drosophila*. *Cell*, 174, 607-621.e618.
- Rings, A., and Goodwin, S.F. (2019). To court or not to court - a multimodal sensory decision in *Drosophila* males. *Curr Opin Insect Sci*, 35, 48-53.
- Roth, A., Vleurinck, C., Netschitailo, O., Bauer, V., Otte, M., Kaftanoglu, O., Page, R.E., and Beye, M. (2019). A genetic switch for worker nutrition-mediated traits in honeybees. *PLOS Biology*, 17, e3000171.
- Ruta, V., Datta, S.R., Vasconcelos, M.L., Freeland, J., Looger, L.L., and Axel, R. (2010). A dimorphic pheromone circuit in *Drosophila* from sensory input to descending output. *Nature* 2010 468:7324, 468, 686-690.
- Ruttner, F. (1966). The Life and Flight Activity of Drones. *Bee World*, 47, 93-100.
- Ruttner, F., and Ruttner, H. (1965). Untersuchungen über die Flugaktivität und das Paarungsverhalten der Drohnen. II Beobachtungen an Drohnensammelplätzen. *Z Bienenforsch.*, 8, 1-9.
- Ruttner, F., and Ruttner, H. (1966). Untersuchungen über die Flugaktivität und das Paarungsverhalten der Drohnen. III. Flugweite und Flugrichtung der Drohnen. *Z. Bienenforsch.*, 8, 332-354.
- Ryner, L.C., Goodwin, S.F., Castrillon, D.H., Anand, A., Vilella, A., Baker, B.S., Hall, J.C., Taylor, B.J., and Wasserman, S.A. (1996). Control of male sexual behavior and sexual orientation in *Drosophila* by the fruitless gene. *Cell*, 87, 1079-1089.
- Salvemini, M., D'Amato, R., Petrella, V., Aceto, S., Nimmo, D., Neira, M., Alphey, L., Polito, L.C., and Saccone, G. (2013). The orthologue of the fruitfly sex behaviour gene fruitless in the mosquito *Aedes aegypti*: evolution of genomic organisation and alternative splicing. *PLoS One*, 8, e48554.
- Salvemini, M., Robertson, M., Aronson, B., Atkinson, P., Polito, L.C., and Saccone, G. (2009). *Ceratitidis capitata* transformer-2 gene is required to establish and maintain the autoregulation of Cctra, the master gene for female sex determination. *The International Journal of Developmental Biology*, 53, 109-120.
- Sandoz, J.C. (2006). Odour-evoked responses to queen pheromone components and to plant odours using optical imaging in the antennal lobe of the honey bee drone *Apis mellifera* L. *Journal of Experimental Biology*, 209, 3587-3598.
- Scheiner, R., Abramson, C.I., Brodschneider, R., Crailsheim, K., Farina, W.M., Fuchs, S., Grünwald, B., Hahshold, S., Karrer, M., Koeniger, G., et al. (2013). Standard methods for behavioural studies of *Apis mellifera*. *Journal of Apicultural Research*, 52, 1-58.
- Schlüns, H., Moritz, R.F.A., Neumann, P., Kryger, P., and Koeniger, G. (2005). Multiple nuptial flights, sperm transfer and the evolution of extreme polyandry in honeybee queens. *Animal Behaviour*, 70, 125-131.

- Schulte, C., Theilenberg, E., Muller-Borg, M., Gempe, T., and Beye, M. (2014). Highly efficient integration and expression of piggyBac-derived cassettes in the honeybee (*Apis mellifera*). *Proc Natl Acad Sci U S A*, 111, 9003-9008.
- Seeley, T.D. (1982). Adaptive Significance of the Age Polyethism Schedule in Honeybee Colonies. *Behavioral Ecology and Sociobiology*, 11, 287-293.
- Smith, M.L., Davidson, J.D., Wild, B., Dormagen, D.M., Landgraf, T., and Couzin, I.D. (2022). Behavioral variation across the days and lives of honey bees. *iScience*, 25, 104842.
- Song, H.J., Billeter, J.C., Reynaud, E., Carlo, T., Spana, E.P., Perrimon, N., Goodwin, S.F., Baker, B.S., and Taylor, B.J. (2002). The fruitless gene is required for the proper formation of axonal tracts in the embryonic central nervous system of *Drosophila*. *Genetics*, 162, 1703.
- Stout, T.L., Slone, J.D., and Schneider, S.S. (2011). Age and Behavior of Honey Bee Workers, *Apis mellifera*, that Interact with Drones. *Ethology*, 117, 459-468.
- Toth, A.L., and Robinson, G.E. (2007). Evo-devo and the evolution of social behavior. *Trends in Genetics*, 23, 334-341.
- Townsend, G.F. (1963). Benzaldehyde: A New Repellent for Driving Bees. *Bee World*, 44, 146-149.
- Turillazzi, S., and West-Eberhard, M.J. (1996). Natural history and evolution of paper-wasps. *Oxford University Press*.
- Usui-Aoki, K., Ito, H., Ui-Tei, K., Takahashi, K., Lukacsovich, T., Awano, W., Nakata, H., Piao, Z.F., Nilsson, E.E., Tomida, J.Y., and Yamamoto, D. (2000). Formation of the male-specific muscle in female *Drosophila* by ectopic fruitless expression. *Nature Cell Biology* 2:8, 2, 500-506.
- van Zweden, J.S., and d'Ettorre, P. (2010). Nestmate recognition in social insects and the role of hydrocarbons. *Insect hydrocarbons: biology, biochemistry and chemical ecology*, 11, 222-243.
- Vargha-Khadem, F., Watkins, K.E., Price, C.J., Ashburner, J., Alcock, K.J., Connelly, A., Frackowiak, R.S.J., Friston, K.J., Pembrey, M.E., Mishkin, M., et al. (1998). Neural basis of an inherited speech and language disorder. *Proceedings of the National Academy of Sciences*, 95, 12695-12700.
- Versteven, M., Vanden Broeck, L., Geurten, B., Zwarts, L., Decraecker, L., Beelen, M., Göpfert, M.C., Heinrich, R., and Callaerts, P. (2017). Hearing regulates *Drosophila* aggression. *Proceedings of the National Academy of Sciences*, 114, 1958-1963.
- Vleurinck, C., Raub, S., Sturgill, D., Oliver, B., and Beye, M. (2016). Linking genes and brain development of honeybee workers: A Whole-Transcriptome approach. *PLoS ONE*, 11, e0157980.
- von Frisch, K. (1967). The Dance Language and Orientation of Bees. *Harvard University Press*.
- Vrontou, E., Nilsen, S.P., Demir, E., Kravitz, E.A., and Dickson, B.J. (2006). fruitless regulates aggression and dominance in *Drosophila*. *Nature Neuroscience*, 9, 1469-1471.
- Wachsmann, A., and Crailsheim, K. (1994). 36. Das Verhalten junger Drohnen (*Apis mellifera carnica* Pollm) im Stock. *Apidologie*, 25, 465-466.
- Wagner, A., Seiler, J., and Beye, M. (2022). Highly efficient site-specific integration of DNA fragments into the honeybee genome using CRISPR/Cas9. *G3*, 12, jkac098.
- Wakonigg, G., Eveleigh, L., Arnold, G., and Crailsheim, K. (2000). Cuticular hydrocarbon profiles reveal age-related changes in honey bee drones (*Apis mellifera carnica*). *Journal of Apicultural Research*, 39, 137-141.

- Wang, L., Han, X., Mehren, J., Hiroi, M., Billeter, J.-C., Miyamoto, T., Amrein, H., Levine, J.D., and Anderson, D.J. (2011). Hierarchical chemosensory regulation of male-male social interactions in *Drosophila*. *Nature Neuroscience*, 14, 757-762.
- Weaverdyck, M.E., and Parkinson, C. (2018). The neural representation of social networks. *Curr Opin Psychol*, 24, 58-66.
- Woyke, J. (1955). Multiple mating of the honeybee queen (*Apis mellifica* L) in one nuptial flight. *Bull. Acad. Polon. Sci. Cl*, 3, 175-180.
- Xu, J., Liu, W., Yang, D., Chen, S., Chen, K., Liu, Z., Yang, X., Meng, J., Zhu, G., Dong, S., et al. (2020). Regulation of olfactory-based sex behaviors in the silkworm by genes in the sex-determination cascade. *PLOS Genetics*, 16, e1008622.
- Yamamoto, D., and Koganezawa, M. (2013). Genes and circuits of courtship behaviour in *Drosophila* males. *Nature Reviews Neuroscience*, 14, 681-692.
- Zhou, C., Franconville, R., Vaughan, A.G., Robinett, C.C., Jayaraman, V., and Baker, B.S. (2015). Central neural circuitry mediating courtship song perception in male *Drosophila*. *eLife*, 4, e08477.
- Zollman, S., Godt, D., Privé, G.G., Couderc, J.L., and Laski, F.A. (1994). The BTB domain, found primarily in zinc finger proteins, defines an evolutionarily conserved family that includes several developmentally regulated genes in *Drosophila*. *Proceedings of the National Academy of Sciences of the United States of America*, 91, 10717-10721.

## Author's Contribution: Manuscript I

### ***fruitless* specifies male group-living behaviors in the honeybee *Apis mellifera***

Journal: Manuscript in preparation for submission to "Cell"

Sven Köhnen, Miriam Müller, Pia Ulbricht, Thomas Eltz and Martin Beye

1<sup>st</sup> author

Author's contribution:

- Concept of study
- Experimental design
- sgRNA synthesis
- Injection of honeybee embryos
- Genotyping of mutant honeybees
- Bee handling for bee tracking
- Dissection of brain tissue, reproductive organs and guts
- Immunohistochemistry and microscope imaging
- Manual video analysis and evaluation of behavioral data
- Sensorimotor assays
- Gut Content analysis
- Data analyses: sequencing data, tracking data, statistics
- Authoring the manuscript

## Manuskript II

### **The gene *fruitless* acts in a subset of the CNS to specify male social behaviors in honeybees**

Sven Köhnen<sup>1</sup>, Julie Carcaud<sup>2</sup>, Pia Ulbricht<sup>1</sup>, Jean-Christophe Sandoz<sup>2</sup> and Martin Beye<sup>1</sup>

<sup>1</sup> Institute of Evolutionary Genetics, Heinrich-Heine University, Dusseldorf, Germany

<sup>2</sup> Evolution, Genomes, Behaviour and Ecology, Université Paris-Saclay, Gif-sur-Yvette, France

Journal: Manuscript in preparation for submission to “Nature Communications”



**Abstract**

Male-specific *fruitless* transcripts are involved in specifying aspects of group-living and mating behavior in honeybee males. We have previously shown that male-specific Fru proteins (Fru<sup>M</sup>) are expressed in the pupal brain, but beyond that, little is known about how *fru* acts at the molecular level. We analyzed the expression pattern of male-specific *fru* products and found that Fru<sup>M</sup> is expressed exclusively in a subset of cells in the CNS. We further analyzed Fru<sup>M</sup> expression in the midbrain and found expression in approximately 1800 cells restricted to the nucleus. Using CRISPR/Cas9-mediated homology-directed repair, we were able to express membrane-tethered GFP under the control of the endogenous P1 promoter to visualize the projection pattern of Fru<sup>M</sup>-expressing cells. We present evidence that these neurons are involved in visual, gustatory and olfactory pathways, as well as in higher-order brain centers, the lateral horn and mushroom bodies. However, *fru<sup>M</sup>* does not act in the periphery of the olfactory pathway, as the expression of chemosensory proteins in the antenna and the development of sexually dimorphic glomeruli were unaffected in *fru* mutants. Furthermore, using calcium imaging, we showed that the neural representation of different odors, including 9-ODA, was unaltered in *fru* mutants, suggesting that *fru* acts in higher-order brain centers to specify male behaviors.

## Introduction

From solitary species to complex societies, animals exhibit a great diversity of sociality (Wilson, 2000). Social behaviors are characterized by interactions among conspecifics that include mating behavior, parental care, or group-living. While solitary living animals may also engage in social behaviors such as mating behavior or parental care at some point in their lives, the behavior of animals living in groups can be characterized by the fact that "two or more individuals maintain spatial and temporal proximity through the mechanism of social attraction." (Ward and Webster, 2016). The most sophisticated form of group-living is referred to as eusociality and can be found in colonies of honeybees, ants or naked mole rats. However, we know little about how such complex social behaviors are specified in the neuronal substrate during development and how the underlying genetic programs have evolved.

The honeybee *Apis mellifera* is a promising model for the study of group-living behaviors for several reasons. First, honeybees are eusocial; second, powerful methods for genetic manipulation are available (Schulte et al., 2014; Roth et al., 2019; Wagner et al., 2022); and third, computer-based tracking of colony members enables precise behavioral analysis (Blut et al., 2017; Gernat et al., 2018; Smith et al., 2022). The honeybee colony typically consists of a reproductive queen, tens of thousands of workers, and a few hundred drones. The ultimate purpose of drones is to reproduce, but they are also adapted to life in the social environment of the colony, where they eventually spend most of their lives. In fact, they interact with sterile workers, which is a social behavior unrelated to reproduction. The most characteristic social non-reproductive related behavior of males is their feeding behavior (Free, 1957; Ohtani, 1974). During the first few days, they are exclusively fed by workers through trophallaxis, a mouth-to-mouth transfer of food. To induce feeding behavior in workers, they approach them and beg for food, to which the workers may respond by offering food from their honey stomachs.

The transcription factor *fruitless* was identified as the first known gene that specifies group-living behaviors in male honeybees (Köhnen et al., 2023). Males carrying a deletion in the P1 region of the *fru* gene (*fru*<sup>P1</sup> males) and lacking male transcripts (*fru*<sup>M</sup>) are less likely to beg for food and less likely to be fed by female workers through trophallaxis. In addition, the length of trophallaxis is shortened in these males.

Not only were interactions with workers impaired, but *fruP1*-drones also showed an altered allocation on the comb and an increase of cell enterings, specifically in the pollen area. This suggests that *fru<sup>M</sup>* also specifies adaptation to the colony environment. The other *fru* transcripts are not sex-specifically spliced.

The *fru* gene is conserved among many insect species, only a fraction of which are eusocially organized. In some of these species, such as *Drosophila melanogaster* (Demir and Dickson, 2005) and in the mosquito *Aedes aegypti* (Basrur et al., 2020), *fru* specifies male mating behavior. Given these facts, *fru<sup>M</sup>* appears to have been co-opted during evolution to specify group-living behaviors. But how does it act at the molecular level? Which tissues and which neuronal pathways are involved?

Previously, we used an anti-Fru antibody to show the expression of the male-specific Fru protein (Fru<sup>M</sup>) in male brains. Typical of transcription factors, the expression was restricted to the nuclei, which prevented us from examining the projection pattern of Fru<sup>M</sup>-expressing neurons. Although we know that cells in the male brain express Fru<sup>M</sup>, we do not know what the neuroanatomy of these cells is, nor do we know whether Fru<sup>M</sup> is expressed in other tissues. Investigating these aspects would be essential for understanding how *fru<sup>M</sup>* specifies group-living behaviors.

Since there are few visual cues in the hive, it stands to reason that olfaction plays a crucial role in mediating these behaviors. Olfaction is known to be essential for a wide range of behaviors in the honeybee (Winston, 1987; Seeley, 1995), and olfactory perception has been extensively studied (Galizia and Menzel, 2000; Galizia and Menzel, 2001; Sandoz et al., 2007; Sandoz, 2011). Odorant molecules are received by olfactory receptors (ORs) in the antenna which are expressed by olfactory sensory neurons (OSNs). OSNs project to spheroidal neuropile units called glomeruli in the antennal lobe. The olfactory system is sexually dimorphic, making it an excellent candidate for an involvement in male-specific behaviors. Drones have approximately 110 glomeruli, compared to ~165 glomeruli in workers and ~155 in queens (Arnold et al., 1985; Brockmann and Brückner, 1999; Brockmann and Brückner, 2001; Nishino et al., 2009; Bastin et al., 2018). Four of these glomeruli are enlarged in males (macroglomeruli, MGs), whereas queens have only one MG and workers have none at all (Arnold et al., 1988; Groh et al., 2006; Groh and Rössler, 2008). To date, little is known about the influence of ORs and MGs on behavior. However, these levels of olfactory perception could provide a basis for the specification of group-living behaviors by *fru*.

One of the odorants whose perception is well described, is the queen pheromone component 9-ODA. It is an attractant for drones (Gary, 1962; Brockmann et al., 2006; Brandstaetter et al., 2014) and is thought to be involved in mating behavior. The olfactory receptor 11 (AmOR11) has a high affinity for 9-ODA (Wanner et al., 2007), and OSNs carrying AmOR11 send their axons to the male-specific MG2, which is known to respond to 9-ODA (Sandoz, 2006). Interestingly, *fruP1*<sup>-</sup> males also showed an altered response to 9-ODA (Köhnen et al., 2023), indicating that *fru* also specifies aspects of mating behavior. Therefore, 9-ODA is an interesting odorant to study the mode of action of *fru*<sup>M</sup> on behavior.

At the behavioral level, we have shown that *fru*<sup>M</sup> specifies aspects of group-living and reproductive behavior, but we have yet to understand which tissues and which neural pathways are involved. Therefore, we set out to analyze the expression of *fru*<sup>M</sup> in different tissues and the projection pattern of Fru<sup>M</sup>-expressing cells and their involvement in different neuronal pathways. We will also investigate the role of *fru*<sup>M</sup> in odor perception in male honeybees.

## Results

### Fru<sup>M</sup> protein is expressed in the male CNS during development

Our previous work showed that the male-specific *fru* transcript (*fru*<sup>M</sup>) is required for the specification of aspects of male group-living and sexual behavior. To understand whether *fru* acts in a specific tissue or organ to specify male behaviors, we examined the expression of *fru*<sup>M</sup> transcripts in different tissues using RT-PCR. We found *fru*<sup>M</sup> to be expressed specifically in neuronal tissues, namely in the brain and in the abdominal ganglia (Fig. 1A; Supplementary Fig. S1), suggesting that these tissues specify the group-living and sexual behaviors. Furthermore, we analyzed the temporal expression of *fru*<sup>M</sup> and found that it is expressed in pupal stages (Supplementary Fig. S3).

To determine the number of cells that are involved in the specification, we next analyzed the expression pattern of Fru<sup>M</sup> in the male brain. In adult midbrain, we found anti-Fru staining in approximately 1800 nuclei of cells that are presumed to be neurons (Supplementary Fig. S2). The stained nuclei are organized in distinct clusters in the anterior and posterior parts of the pupal brain, as well as in regions that span parts of

the anterior and posterior brain (Fig. 1B). Distinct clusters were also detected in the meso-metathoracic ganglion (Supplementary Fig. S4). Together, these results suggest that the specification of the group-living behaviors involves a small subset of approximately 1800  $Fru^M$ -expressing cells compared to the approximately 1,000,000 cells (Menzel, 2012) of the honeybee brain and ganglia.

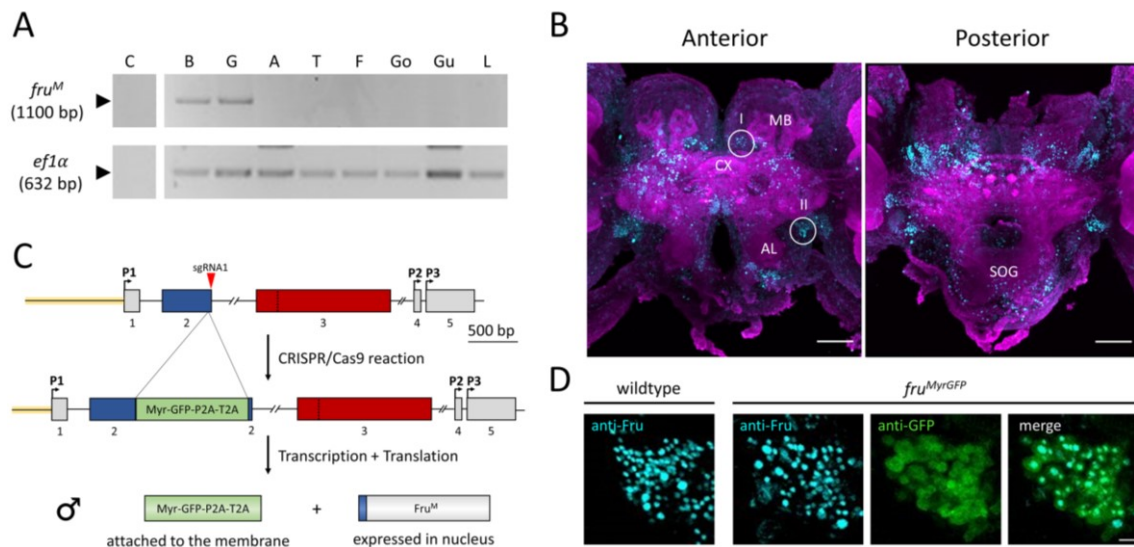

**Figure 1.** **A.** Male specific *fruitless* transcript ( $fru^M$ ) in different tissues of adult wt drones. Transcripts were amplified by RT-PCR and size resolved. PCRs were semi-quantitatively adjusted using the *ef1α* gene as a control. **B.** Brain, G: Abdominal ganglia, A: Antenna, T: Dorsal half of thorax, F: Fat body, Go: Gonads, Gu: Gut, L: Hindlegs. **B.**  $Fru^M$  expression in midbrain of wt male. Midbrain of adult P3 pupae was stained with anti- $Fru$  (green) and phalloidin (f-actin, magenta). MB: mushroom body, AL: antennal lobe, CX: central complex, SOG: subesophageal ganglion. Cluster I and II are circled. Scale 100  $\mu$ m. **C.** Scheme of the Insertion of a Myr-GFP-P2A-T2A sequence into the *fru* gene. Boxes are exons, different promoters are indicated (P1-P3). A double-strand break was induced by the Cas9 protein at the sgRNA1 target site (red arrow). The donor sequence (green) was then inserted into exon 2 (blue box) by homologous directed repair. In males, the female-specific exon 3 (red box) is spliced out. During translation, the protein encoded by the donor sequence and  $Fru^M$  are separated by ribosomal skipping. As a result, Myr-GFP-P2A-T2A is attached to the membrane, while  $Fru^M$  is expressed in the nucleus. **D.**  $Fru^M$  and GFP expression in Cluster I. A wildtype adult brain was stained with anti- $Fru$  (magenta). The corresponding region in a brain of a  $fru^{MyrGFP}$  male was double stained with anti- $Fru$  (magenta) and anti-GFP. Images were also merged. Scale 10  $\mu$ m.

### Inserted *MyrGFP* sequence identifies $Fru^M$ -expressing neurons

To identify the neuronal pathways of  $fru^M$ -expressing neurons involved in male behaviors, we co-expressed membrane-tethered GFP with  $Fru^M$ .

We used CRISPR/Cas9-mediated homology-directed repair to insert *MyrGFP* and the P2A and T2A endopeptidase coding sequences into exon 2 of the *fru* gene (Fig. 1C;

Supplementary Fig. S5; Jinek et al., 2012; Roth et al., 2019; Wagner et al., 2022). The aim of this insertion was to express the MyrGFP protein as well as the Fru<sup>M</sup> protein under control of the endogenous P1 promoter in the males. To test this, we stained brains of mutant males (*fruP1<sup>MyrGFP</sup>*) with anti-Fru and anti-GFP staining and studied the co-localization of the signals in two distinct clusters, one in the anterior region of the superior protocerebrum (cluster I; Fig. 1B) and the other ventral to the protocerebral lobe above the antennal lobe (cluster II; Fig. 1B). As shown previously, anti-Fru staining was confined to the nucleus (Fig. 1D; Köhnen et al., 2023). It appeared that anti-GFP staining was detected in the entire cells with accumulation in the membrane, suggesting that the two proteins are separated during translation (Fig. 1D). To exclude that the insertion of the GFP sequence into the *fru* locus affects the number or formation of neurons, we compared the number of cell nuclei with anti-Fru staining between wt and *fruP1<sup>MyrGFP</sup>* males in the two clusters and found no differences (Fig. 1D; Supplementary Fig. S6; Cluster I: Mann-Whitney,  $z = -0.74$ ,  $P = 0.54$ ; Cluster II: Mann-Whitney,  $z = -1.0$ ,  $P = 0.33$ ). To determine whether all anti-Fru-stained cells also exhibited GFP expression, we examined the number of cells showing co-expression of anti-Fru and anti-GFP staining. We found that on average 100% of cells in cluster I (approximately 78 cells) and 96% cells in cluster II (approximately 23 cells) co-expressed both proteins (Fig. 1D; Supplementary Table S1 and Supplementary Fig. S7). These results demonstrate that the membrane-tethered GFP expression is a reliable representation of the Fru<sup>M</sup>-expressing neurons and thus plausible also for their projections in the male brain. We next followed the neuronal pathways of the Fru<sup>M</sup>-expressing cells.

### **Fru<sup>M</sup>-expressing neurons connect peripheral sensory perception to higher-order processing centers**

To determine possible neuronal processing pathways involved in group-living and sexual behaviors, we examined the projection patterns of myrGFP- labeled cells in *fruP1<sup>myrGFP</sup>* males (Fig. 2A-F). We observed GFP labeling in the antennal nerve, in a subset of neurons in the glomeruli of the antennal lobes (including the male-specific macroglomerulus MG2 associated with 9-ODA perception) (Fig. 2K), and suboesophageal ganglion (Fig. 2E), suggesting that first-order neuropils for olfaction

and gustation are involved in a neuronal circuit expressing Fru<sup>M</sup>. We also found distinct clusters of Fru<sup>M</sup>-expressing neurons in the lateral horn (Fig. 2G), the next higher order processing center for olfactory information.

We observed that specific areas in the mushroom bodies (MBs) were labeled (Fig. 2H), suggesting that further upstream elements of the chemosensory pathway are potentially specified by Fru<sup>M</sup> protein. This is the lip, which is associated with olfactory information processing (Schröter and Malun, 2000; Abel et al., 2001), and the outer collar zone (Strausfeld, 2002), which receives visual input from the lobula and medulla optical tracts (Gronenberg, 1986; 2001). Two different divisions of the vertical lobe, namely the division corresponding to the basal ring (Dbr) and division corresponding to the collar (Dco), which receive information from the basal ring and the collar, respectively, were also labeled (Fig. 2I). These regions represent the output region of the MBs (Mobbs, 1984; Rybak and Menzel, 1993; Strausfeld, 2002).

Neurons in the anterior optic tubercle (Fig. 2J) were also labeled, suggesting that visual pathway information processing may also be involved in the Fru<sup>M</sup> circuitry. There may be other elements of a Fru<sup>M</sup>-expressing neuronal circuitry, which we cannot rigorously detect at this level of analysis, which is limited by the amount of GFP expression and the detection capabilities of light microscopy. Taken together, however, these results suggest that Fru<sup>M</sup>-expressing neurons are involved in the perception and processing of different sensory modalities (olfaction, vision, and gustation) and convey information to higher-order processing centers such as the mushroom bodies.

*fru*<sup>MyrGFP</sup>

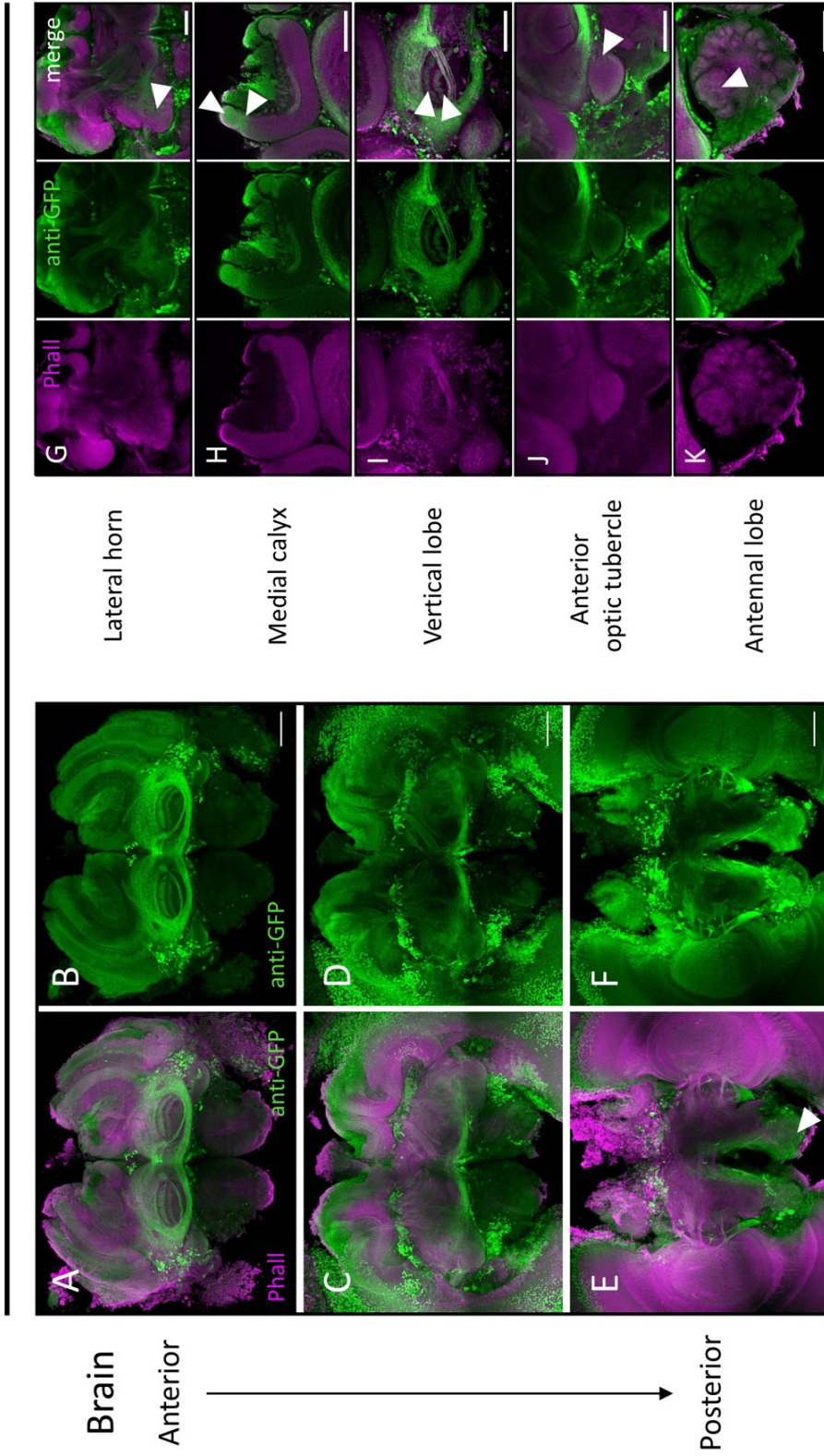

**Figure 2. Projection pattern of GFP-expressing cells in the male honeybee brain.** Confocal images of a *fru*<sup>MyrGFP</sup> male brain showing phalloidin (f-actin, magenta) and anti-GFP (green) expression. Anterior (A), medial (C) and posterior (E) regions of the brain. The anti-GFP channel is also shown separately for each image (B, D and F). GFP expression in the SOG is indicated by an arrowhead (E). G. GFP expression in the lateral horn. H-K. Higher magnification images (40x). Phalloidin (f-actin, magenta) and anti-GFP (green) channels are shown separately, as well as the overlap. H. GFP expression in the lip (upper arrowhead) and in the outer collar zone (lower arrowhead) of the calyxes. I. GFP expression in different divisions of the vertical lobe. Upper arrowhead: division corresponding to the basal ring; lower arrowhead: division corresponding to the collar. J. GFP is expressed in the anterior optic tubercle (AOT, arrowhead). K. Staining in the antennal lobe, macroglomerulus 2 (MG2) is indicated (arrowhead). Scale 100 µm.



### ***fru<sup>M</sup>* does not control genes expressing the peripheral chemosensory perception system**

Next, we sought to understand the molecular and cellular mechanisms that specify male behaviors in neuronal tissue. Olfaction is a central sensory modality for the bees within the colony. Olfactory sensory neurons (OSNs) in the antennae express chemosensory receptors and binding proteins for the detection of molecules from the environment. To understand whether *fru<sup>M</sup>* regulates the molecular inventory for the detection and transport of these molecules at the sensory periphery, we studied the expression of odorant receptor (OR), odorant binding protein (OBP), gustatory receptor (GR) or chemosensory protein (CSP) genes in the antennae. We observed no differentially expressed transcripts of OR or OBP genes between males lacking exons 1 and 2 (*fruP1<sup>-</sup>* males; Köhnen et al., 2023) and wt males (Supplementary Fig. S9). This also holds for the *AmOr11* gene, which is involved in 9-ODA perception (Wanner et al., 2007). This result suggests that *fru<sup>M</sup>* does not control the specific expression of odorant receptors and odorant binding proteins to enable the male-specific behaviors. We also found no differences in gene expression for GRs or CSPs (Supplementary Fig. S9). Taken together, these results suggest that *fru<sup>M</sup>* does not specify the male behaviors by regulating specific chemosensory proteins at the sensory periphery.

### **Development of sexually dimorphic macroglomeruli in antennal lobes is not affected by *fru<sup>M</sup>***

To investigate whether the male-specific *fru* transcripts determine the sexual dimorphism of the antennal lobe, we examined the anatomy of *fruP1<sup>-</sup>* males. The antennal lobe is the primary olfactory center of the brain. It consists of spheroidal neuropile units called glomeruli. Female and male antennal lobes are sexually dimorphic, as drones have 4 hypertrophied glomeruli (macroglomeruli, MGs) and a lower total number of glomeruli (Fig. 3A; Arnold et al., 1985; Brockmann and Brückner, 1999; Brockmann and Brückner, 2001; Nishino et al., 2009; Bastin et al., 2018). Male-specific MG2 receives input from olfactory sensory neurons carrying *AmOr11*, which is known to respond to the queen sexual pheromone 9-oxo-(E)-2-decenoic acid (9-ODA) (Sandoz, 2006; Wanner et al., 2007). We stained the AL tissue with an anti-

synapsin antibody and examined microscopical sections. We found no differences in the gross morphological organization of MGs in *fruP1*<sup>-</sup> versus wt males (Fig. 3A). These were clearly different from the glomeruli of the worker female bees (Fig. 3A). Although we cannot exclude the possibility that there are more subtle differences, for example, in the volume of MGs, this result suggests that *fru<sup>M</sup>* protein is not required for the development of this gross sexual dimorphism. We conclude that *fru<sup>M</sup>*-dependent male behaviors are not specified via the gross anatomical differences of MGs in the glomeruli.

### **The first-order processing of 9-ODA and other odors in the AL is not specified by *fru<sup>M</sup>***

To determine whether Fru<sup>M</sup> protein specifies the information processing in the AL at the physiological level, we studied the neuronal activity in *fruP1*<sup>-</sup> males using a Ca<sup>2+</sup> activator and different odors. First, we tested the repellent benzaldehyde, an odor to which the *fruP1*<sup>-</sup> and wt males responded in our behavioral assay (Köhnen et al., 2023). In the *in vivo* optical imaging experiments, we found strong calcium signals and specific glomeruli activity patterns that did not differ between *fruP1*<sup>-</sup> and wt males (Fig. 3B and C). Next, we tested isopentyl acetate, which is a component of the alarm pheromone. We found a specific glomeruli activity pattern which did not differ (Fig. 3B and C). For the odor 9-ODA, we found a strong and specific signal for MG2, as expected (Fig 3D and E; 2-Way Repeated measures ANOVA, odor effect, F<sub>2,48</sub>=65.25, p<0.0001; Tukey post-hoc tests, 9-ODA vs iso, p<0.0001). We limited our quantitative analysis to MG2 and found no differences in Ca<sup>2+</sup> signal between *fruP1*<sup>-</sup> and wt males (Fig. 3E; 2-Way Repeated measures ANOVA, genotype effect, F<sub>1,24</sub>=0.571, p=NS or 0.4572; Sidak multiple comparison test, 9-ODA WT vs 9-ODA *fruP1*<sup>-</sup> drones, p=NS or 0.3555). We found a significantly lower signal for isopropanol, which served as a control since we employed it for the initial solution of 9-ODA (Fig. 3E). These results suggest that gross general first-order processing of the odors was not compromised in *fruP1*<sup>-</sup> males.

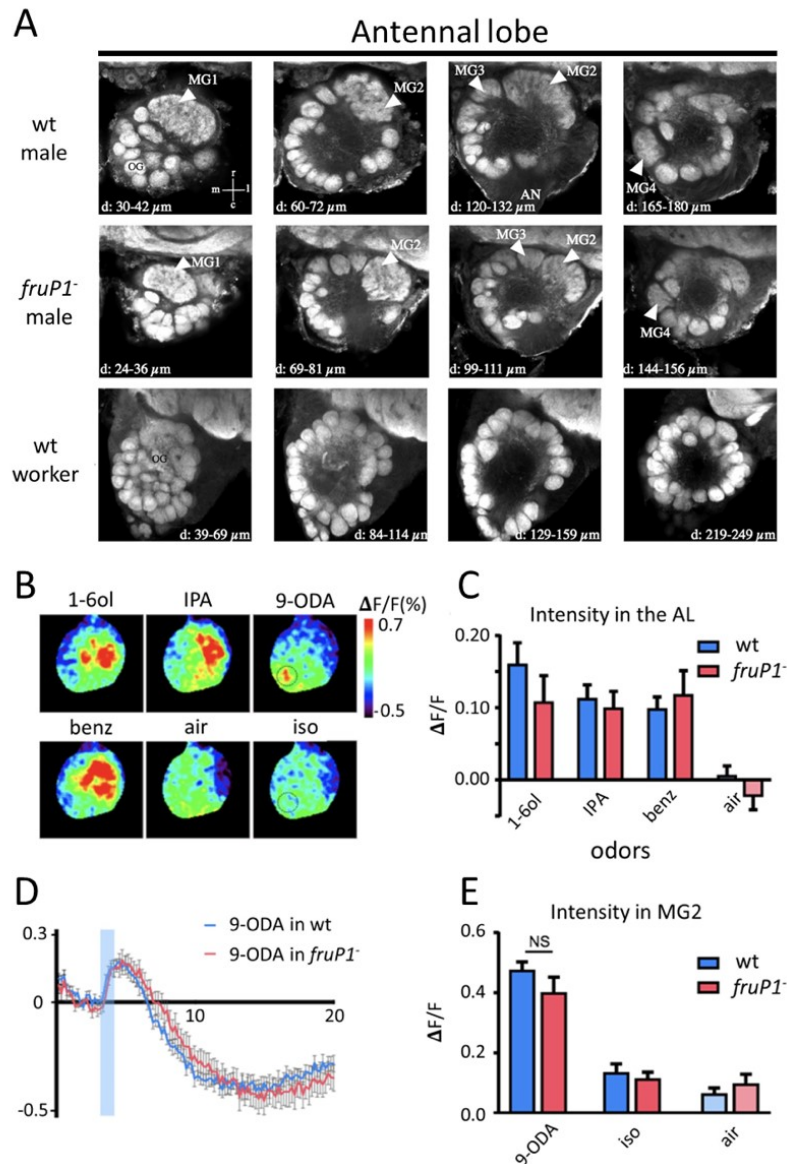

**Figure 3.** The effect of *fru<sup>M</sup>* on odor processing in the antennal lobe. **A.** Morphology of the antennal lobes of a wt male, a *fruP1*<sup>-</sup> and a worker bee. Images at different depths are shown (indicated in each image, d=XX μm). Macroglomeruli are indicated with arrowheads. **B.** Calcium signals in the antennal lobe evoked by a panel of 3 odorants (1-6ol, IPA, benzaldehyde (benz)), the queen pheromone compound 9-ODA and 2 controls (air and isopropanol). Different odorants induce different glomerular activity patterns. Relative fluorescence changes ( $\Delta F/F$  [%]) are presented in a false-color code, from dark blue (minimal response) to red (maximal response). The map shows the whole amplitude of the response, including both positive and negative components. The dashed circle indicates the localization of the male macroglomerulus MG2. **C.** Amplitude of calcium responses ( $\Delta F/F$  [%]) recorded in the whole AL to the 3 volatile odorants (1-6ol, IPA and benzaldehyde) and to the air control. All odorants induce significant activity in comparison to the air control (*fruP1*<sup>-</sup> in red, n = 11 and wt males in blue, n = 16, \*\*\*  $p < 0.0001$ ). **D.** Average time courses of odor-evoked responses ( $\Delta F/F$  [%]) recorded in MG2 to 9-ODA in *fruP1*<sup>-</sup> (in red, n = 10) and wt males (in blue, n = 16). Calcium signals show a biphasic response, with a fluorescence increase upon odor presentation (blue bar) followed by a long undershoot. **E.** Amplitude of calcium responses ( $\Delta F/F$  [%]) recorded in MG2 to the queen pheromone 9-ODA and to the air and solvent controls. The 9-ODA induces significant activity in MG2 in comparison to the controls (*fruP1*<sup>-</sup> in red, n = 10 and wt males in blue, n = 16, \*\*\*  $p < 0.0001$ ), with no difference between wt and *fruP1*<sup>-</sup> males.

## Discussion

Group-living behaviors in honeybees are crucial for the functioning of the colony. The role of males in the colony social network has long been underestimated, with males thought to be primarily responsible for reproduction and secondarily consuming the colony resources. We recently showed that male-specific transcripts of a single gene, *fru*, specify distinct aspects of group-living and reproductive-related behavior in honeybee males. However, we do not know how *fru<sup>M</sup>* acts at the molecular level and whether neuroanatomical or neurophysiological differences cause sex-specific behaviors between males and females. In this study, we demonstrate that Fru<sup>M</sup> is expressed in neuronal tissues during development, and that some of the Fru<sup>M</sup>-expressing neurons are involved in pathways of different sensory modalities. In particular, certain cells involved in the olfactory pathway show sexual dimorphism. However, *fru<sup>M</sup>* is not essential for the development of sexually dimorphic macroglomeruli (MGs) or for the expression of chemosensory proteins in the antennae.

### ***fru<sup>M</sup>* sets potential for male behaviors during development in CNS**

Using RT-PCR, we consistently found *fru<sup>M</sup>* expression in the brain and in abdominal ganglia (Fig. 1A and Supplementary Fig. S1), indicating that *fru<sup>M</sup>* expression is mostly restricted to the central nervous system (CNS). This suggests that male-specific behaviors are specified in the nervous system rather than being influenced by other tissues. Although we have no evidence for expression in other tissues, we cannot exclude the possibility that *fru<sup>M</sup>* acts in non-neuronal tissues to influence the behavior. For instance, the fat body influences male courtship behavior in *D. melanogaster*. Feminization of this tissue resulted in a greatly reduced ability of males to exhibit courtship behavior (Lazareva et al., 2007).

We also showed that *fru<sup>M</sup>* is expressed during development in the pupal stages (Supplementary Fig. S3). This is an important finding because the insect brain undergoes a significant reorganization process during this stage (Tissot and Stocker, 2000). This spatial and temporal expression indicates that *fru<sup>M</sup>* acts during development to create the potential for the specific behaviors. In *D. melanogaster*, where the spatial and temporal expression patterns of *fru* are very similar to those found in honeybees (Ryner et al., 1996; Lee et al., 2000), experiments have shown

that male-specific mating behaviors are irreversibly programmed during the pupal stages (Arthur et al., 1998). However, we also found that the Fru<sup>M</sup> protein is expressed in the adult brain. Therefore, a direct influence of *fru<sup>M</sup>* on neurophysiology in the adult brain cannot be excluded.

### **Projection patterns reveal involvement of Fru<sup>M</sup>-expressing neurons in different sensory modalities and different processing levels**

We applied a highly efficient and site-specific integration of a donor sequence into the open reading frame of P1 transcripts using the CRISPR/Cas9 system (Jinek et al., 2012; Wagner et al., 2022). We showed that the reporter protein GFP was expressed in the membrane of the Fru<sup>M</sup>-expressing cells and, equally important, that Fru<sup>M</sup> expression remained largely unaffected, although we cannot exclude the possibility that the amount of Fru<sup>M</sup> protein expressed in the nuclei is slightly reduced in *fru<sup>MyrGFP</sup>* individuals (Supplementary Fig. S6 and S7). This suggests that both proteins were separated during translation due to P2A- and T2A-induced ribosomal skipping (Donnelly et al., 2001; Sharma et al., 2012). This will allow future analysis of the projection patterns of cells expressing any gene of interest.

The resulting projection pattern showed that neurons of different sensory modalities and multiple processing levels in the brain express Fru<sup>M</sup> (Fig. 2A-E). We found GFP expression in regions that process visual, olfactory, and gustatory information, such as the optic lobes, antennal lobes, and subesophageal ganglion (SOG). We also found expression in higher order processing centers such as the lateral horn (LH) and the mushroom bodies (MBs). While the MBs serve as multisensory integration centers, the LH is thought to act as an integration center that triggers innate responses to odors (Strutz et al., 2014). It has been suggested that the LH is involved in triggering male mating behavior in honeybees (Mariette et al., 2021). In addition, we observed GFP expression in the meta-mesothoracic, indicating widespread expression in the CNS, making it likely that circuits of *fru<sup>M</sup>*-expressing cells exist.

These results are particularly interesting in light of the behavioral impairments found in *fruP1*<sup>-</sup> drones. We believe that there are impairments in two different mechanisms. First, we discovered that the mutant drones exhibit a gain of cell enterings in the pollen area (Köhnen et al., 2023). This suggests that a stereotypical motor neuron program

is activated in the wrong context (pollen odor). We believe that this decision-making process may be associated with higher-order decision-making centers such as the MBs or the LH. Second, we found that *fruP1*-drones show a significant reduction in interactions with workers (Köhnen et al., 2023). Based on this observation, we suggest that the decision-making process that triggers specific behaviors is impaired. This defect could occur at different levels of processing, but we hypothesize that the ability to recognize the relevant cue that triggers the behavior is compromised. This defect is likely to occur in the periphery, where olfactory, gustatory, or visual signals may not be detected, or information processing is compromised.

GFP expression in the anterior optic tubercle (Mota et al., 2011) suggests an involvement of *fru<sup>M</sup>* in the processing of visual information, but we assume that this involvement is primarily related to mating behavior rather than to group-living behavior in males. While visual cues are thought to be critical for the formation of drone congregation areas, where mating occurs (Koeniger G, 2014), these are relatively rare in the hive. Moreover, GFP staining in the SOG provides clear evidence for the involvement of gustatory pathways in the action of *fru*. Although the response of honeybees to sucrose has long been studied, little is known about the influence of taste perception on group-living behaviors in males. Worker bees and foraging have been the primary focus of most studies.

Overall, we believe that the olfactory pathway is most likely to play a crucial role in group-living behaviors. We observed GFP staining in critical structures of this pathway, including the antennal lobes, lateral horn, and mushroom bodies. Of particular interest to us was the observation that the response to a specific odorant, the queen pheromone component 9-ODA, was impaired in *fruP1*-males in a previous study (Köhnen et al., 2023). Therefore, we decided to investigate the olfactory pathway in more detail.

### **Fru<sup>M</sup> is expressed in sexually dimorphic neurons, but is not essential for their formation**

We conducted transcriptome analysis to analyze the periphery of odor perception. We found no differential expression of *AmOR11*, the specific receptor for 9-ODA, in the antennae of *fruP1*-males, indicating that *fru<sup>M</sup>* is not required for the expression of this olfactory receptor (Supplementary Fig. S9). This is in contrast to previous research in

the silk moth *Bombyx mori*, where the absence of *fru<sup>M</sup>* resulted in the downregulation of the *BmOR3* olfactory receptor, which is specific for a female sex pheromone (Xu et al., 2020). Despite the conserved gene structure and sex-specific splicing of *fru* in these two organisms, our findings suggest that *fru* may function differently in honeybees and silk moths, at least at the level of olfactory perception. However, we did not find differential expression in any other chemosensory protein genes, making it unlikely that *fru* specifies group-living behaviors at this level of the olfactory pathway (Supplementary Fig. S9).

The next unit in odorant processing is the antennal lobe, which contains four male-specific macroglomeruli, one of which is MG2. MG2 is activated by 9-ODA, making it a likely candidate for involvement in the specification of male-specific reproductive behaviors. The presence of GFP-expressing neurons within MG2 suggests that there are sexually dimorphic *fru<sup>M</sup>*-expressing neurons, indicating that at least some behavioral differences between males and females are due to differences in neuroanatomy (Fig. 2K). These findings are consistent with studies in *D. melanogaster*, where male-specific and sexually dimorphic neurons, and even entire neural circuits, have been identified (Kimura et al., 2005; Kimura et al., 2008; Ruta et al., 2010).

Interestingly, we found that MG2 was still present in *fruP1*<sup>-</sup> drones, demonstrating that *fru<sup>M</sup>* is not essential for the formation of this sexual dimorphism in the glomeruli (Fig. 3A). One candidate gene that could specify this dimorphism is *doublesex (dsx)*, another gene in the sex determination cascade that is responsible for the development of sexually dimorphic structures in a variety of insect species. For example, loss of function of *dsx* leads to malformation of reproductive organs in species such as *D. melanogaster* (Camara et al., 2019), *B. mori* (Xu et al., 2017), and *Nilaparvata lugens* (Zhuo et al., 2018). Defects in mouthparts and antennae have been identified in *Aedes aegypti* (Mysore et al., 2015) and *Anopheles gambiae* (Kyrou et al., 2018). In honeybees, mutant females also have size-reduced reproductive organs (Roth et al., 2019). In addition, *dsx* also affects male mating behavior in *D. melanogaster*. Mutant females expressing Fru<sup>M</sup> are able to perform some parts of the male courtship song correctly, but only those that also express Dsx<sup>M</sup> are able to perform the complete courtship song (Rideout et al., 2007). *dsx* also affects the specification of male mating behavior in the brain. P1 is a *fru*-expressing cluster in the brain. P1 neurons are present only in the male brain and are important for initiating courtship behavior. The absence of these neurons in females is due to Dsx<sup>F</sup>-induced programmed cell death. When Fru<sup>M</sup>

and  $Dsx^M$  are expressed in females, the P1 neurons are present, and they can initiate courtship behavior (Kimura et al., 2008). Recently, another gene responsible for the development of sexually dimorphic structures in the honeybee has been described. The gene *glubschaug* (*glu*) has been shown to be involved in the development of sexually dimorphic eyes (Netschitailo et al., 2023).

Having established that MG development is not affected by  $fru^M$ , we used calcium imaging to test whether the neural representation of different odors is also unaffected. We showed that 9-ODA also elicits activity in MG2 of *fruP1*<sup>-</sup> drones and that the activity patterns of other odors were also the same as in wt males (Fig. 3). Overall, this suggests that this aspect of reproductive behavior is not specified at the level of the antenna or antennal lobe, but in subsequent parts of the pathway.

Projection neurons (PNs) convey processed information from MG2 to the LH and MBs via the lateral antennal lobe tract (l-ALT) (Kropf et al., 2014). Because the LH appears to trigger innate responses to specific odors, it is also thought to be involved in triggering mating behavior (Mariette et al., 2021). As noted above, male mating behavior depends on at least one other modality, vision. It is speculated that the 9-ODA signal is contextualized with other modalities in the mushroom bodies (Rybak and Menzel, 1993; Mariette et al., 2021). LHs and MBs both involve  $fru^M$ -expressing neurons, making them intriguing candidate structures for further analysis.

But what about group-living behaviors? Does  $fru^M$  specify these behaviors at the level of odor detection (in the antenna) or at the level of first-level processing (in the antennal lobe)? It seems unrealistic that  $fru^M$  specifies these behaviors at the level of the antenna (periphery), since we found no differences in chemosensory protein expression. The most striking group-living behaviors are interactions with non-sexual workers. A possible next step would be to analyze the activity patterns in the antennal lobes of *fruP1*<sup>-</sup> drones elicited by worker odors. Differences in the neural representation of these odors could explain the reduction of worker interactions in mutant drones. If this is the case, it would indicate a different mechanism in the functioning of  $fru^M$ , since it is not required at this level to process queen pheromones.



## **Are there *fru<sup>M</sup>*-expressing neurons that are unique to group-living behaviors?**

We have come a step closer to understanding the function of *fru<sup>M</sup>* in specifying group-living behaviors. However, there are still some important questions to be answered. Are there neurons that express *fru<sup>M</sup>* that are male-specific? As mentioned above, there are few sexually dimorphic or male-specific neurons in *D. melanogaster*. To answer this question, we need to insert GFP into the *fruP1* open reading frame of females and compare the projection patterns with those of *fru<sup>MyrGFP</sup>* males. Assuming that there are male-specific *fru<sup>M</sup>*-expressing neurons, the next question is whether *fru<sup>M</sup>* is essential for the formation of this sexual dimorphism. To address this question, double mutant males should be generated. These mutants should express the GFP protein but contain a translational stop in the *fru<sup>M</sup>* sequence. The final and probably most difficult question to answer is whether the same neurons are involved in both behaviors or whether there are unique neuronal anatomical and molecular features specifically dedicated to group-living behaviors. In this case, mosaic studies would be required in which the *fru<sup>M</sup>* transcript is absent in only a subset of *fru<sup>M</sup>*-expressing cells.

## **Methods**

### **Honeybee source**

The colonies were located in the bee yard or the containment at the Heinrich-Heine University Düsseldorf, Germany. The genetically modified honeybees were maintained together with worker bees in small mating nucleus hives (Segeberger nucs), which we kept in a secure containment (flight cage or laboratory), so that genetically modified animals could not escape into nature.

### **CRISPR/Cas9 procedure**

*fru<sup>MyrGFP</sup>* males:

*fru*-sgRNA 1 was synthesized and purified as previously described (Roth et al., 2019). The target site (sgRNA1: GTGTTTGGCGCATCGTTACC, -1) was identified using

Benchling (Biology Software, <https://benchling.com>) and is located 22 bp downstream of the start codon.

The *fru-Myr-GFP-P2A-T2A-fru* fragment was synthesized as a 1638 bp long (double-stranded molecule GeneStrands, Eurofins, Ebersberg, Germany). We fused the *Myr*, *GFP*, *P2A*, and *T2A* coding sequences linked by Gly–Ser–Gly (GSG) linker sequences (Supplementary Fig. S5; Szymczak-Workman et al., 2012). We added an additional start codon at the end of the *T2A* to ensure that the following fruitless sequence would be translated correctly. The resulting sequence was flanked by two homologous arms (each 250 bp long) corresponding to the sequence of intron 1 and exon 2 and intron 2, respectively, of the *fruitless* gene [NCBI; gene ID: 409022; Reference Sequence: NC\_037646; Assembly: Amel\_HAV3.1 (GCF\_003254395.2)]. We modified the PAM site using homologous directed repair (HDR) so that the sequence would not be targeted again by the Cas9 protein (Wagner et al., 2022). The donor sequence used for HDR was amplified with oligonucleotides SK54/SK23 (Custom DNA Oligos, Eurofins) and purified as previously described (Wagner et al., 2022). Diploid female eggs were collected from wild-type queens every 90 minutes and injected directly with 53-mm injection needles (Hilgenberg, Malsfeld, Germany) (Schulte et al., 2014; Roth et al., 2019). We injected 375 ng/μl of Cas9 protein (EnGen Cas9 NLS, *S. pyogenes*, #M0646, New England Biolabs), sgRNA1 and donor DNA in a molar ratio of 1:1:1. *fruP1* males had the same genotype as described in Köhnen et al. (2023).

### Queen rearing and bee handling

The injected eggs were reared to queens as described in Schulte et al. (Schulte et al., 2014). The genotype of the resulting queens was determined by PCR amplifications (see DNA preparation). Mutant queens were treated twice with CO<sub>2</sub> (on day 9 and day 10) to stimulate oviposition of unfertilized eggs, which developed into males. The queens were maintained together with worker bees in "Kieler Begattungskästen" (KBK; Holtermann, Germany) placed in a flight cage. Capped brood frames of *fru<sup>MyrGFP</sup>* queen colonies were placed in an incubator at 34°C. Brains of freshly emerged drones were dissected and analyzed.

## DNA and RNA preparation and PCR procedures

Genomic DNA was isolated from two opposing legs using the innuPREP DNA Mini Kit (Analytik Jena, Jena, Germany).

Total RNA was isolated using a Trizol-based protocol (Vleurinck et al., 2016).

For different stages of development: Whole larvae aged 6-7 days and 11-12 days, pupal heads aged 14-15 days and 19-20 days. We pooled 3 individuals of each developmental stage to create 3 pools of each stage.

For different tissues: Brain, abdominal ganglia, antenna, dorsal half of the thorax, fat body, gonads, gut and hindleg. We pooled the same tissue from 5 individuals each, creating 3 pools of each tissue.

Each sample was homogenized with a pestle in 250 µl Trizol reagent, vortexed for 30 seconds, and incubated for 5 minutes at room temperature. 50 µl of chloroform was added to the samples, vortexed for 30 seconds, and incubated at for 5 minutes at room temperature. After centrifugation for 15 minutes at 4 °C and 13,000 rpm, the upper phase was combined with an equal volume of isopropanol. The samples were then incubated for 10 minutes at room temperature and subsequently centrifuged for 10 minutes at 4 °C and 13,000 rpm. The RNA pellet was washed with 250 µl of 70 % ethanol, dried, and dissolved in 23 µl nuclease free water. First-strand cDNA was synthesized using the RevertAid First Strand cDNA Synthesis Kit (Thermo Scientific).

To analyze *fruP1* transcripts, we amplified the cDNA using PCR and oligonucleotide primers SK60/SK61. The gene *elongation factor 1-alpha* was used to adjust cDNA samples for the semiquantitative analysis. Amplicons were resolved using agarose gel electrophoresis.

To identify and characterize the mutations, genomic DNA of the target region was amplified by PCR (Hasselman and Beye, 2004) using Phusion High-Fidelity DNA Polymerase. For the fru-Myr-GFP-P2A-fru fragment, we performed one PCR for the first half (oligonucleotide primers SK29/56) and one for the second half (oligonucleotide primers SK55/27) of the fragment. Amplicons were cloned into pGEM-T Easy Vector (Promega, Madison, WI). We examined the progeny of two mutant queens, Q22 and Q34. We have characterized the mutations of 3 different offspring from Q22 and only

one from Q34, as this was the only individual included in the analysis. For this purpose, at least 3 clones of each offspring were sequenced on both strands by Sanger sequencing (Eurofins, Ebersberg, Germany). Oligonucleotides were provided by Eurofins Genomics (Ebersberg, Germany) and the sequences are listed in Supplementary Table S2.

### **Immunohistology and imaging of brains and ganglia**

For whole mounts, brains or ganglia of male and female bees were dissected in ice-cold honeybee saline (130 mM NaCl, 5 mM KCl, 4 mM MgCl<sub>2</sub>, 5 mM CaCl<sub>2</sub>, 15 mM Hepes, 25 mM glucose, 150 mM sucrose, pH 7.2) and fixed in 4% ice-cold formaldehyde (Roth, Karlsruhe, Germany) in phosphate-buffered saline (PBS, pH 7.2) at 4°C for at least 24 hours. Brains were washed 3 x 10 minutes in PBS, 1 x 10 minutes in PBS containing 2% Triton X-100 (PBS-T), and 2 x 10 minutes in 0.2% PBS-T. All washing steps were performed at room temperature on a shaker. Brains were blocked for 1 hour at room temperature in 0.2% PBS-T containing 2 % normal goat serum (NGS) (blocking solution) and incubated with 0.2 units of Alexa Flour 568 phalloidin (Molecular Probes, A-12380, Eugene, USA) and rabbit-anti-Fruitless antibody (1:2000) in blocking solution for 4 days at 4°C. For *fru*<sup>MyrGFP</sup> male brains, chicken-anti-GFP antibody (1:1000; Rockland Immunochemicals, Inc., Limerick, PA, USA) was added. Brains were then washed 3 time for 1 hour and incubated with goat-anti-rabbit secondary antibody (1:250; Fisher Scientific, Schwerte, Germany) in 0.2 % PBS-T containing 2 % NGS for 2 days at 4 °C on a shaker. For *fru*<sup>MyrGFP</sup> individuals, goat-anti-chicken antibody (1:250; Fisher Scientific, Schwerte, Germany) was added. After washing 4 x 5 minutes in PBS, the brains were dehydrated in an isopropanol series (10, 30, 50, 70, 90% isopropanol in PBS and 2 x 100 % isopropanol, 5 minutes each step) and then cleared in methylsalicylate (MS 99%; Sigma Aldrich, Steinheim, Germany) before being mounted in fresh MS and stored at 4 °C under dark condition until imaging.

Optical sections for all z-stacks were taken at 3 µm intervals with a resolution of 512 x 512 pixels. We generated image z-stacks of one hemisphere of midbrains and ganglia. In addition, we generated tile scans of whole brains, which were merged using the

processing tool Mosaic Merge of LAS X (Leica Application Suite X 3.0.0, Leica Microsystems CMS, Wetzlar, Germany) with a 20x objective (multi/ NA 0.75). In Additionally, z-stacks of selected brain regions were imaged using a 40x objective (water/ NA 1.10). Images were processed using FIJI (ImageJ 1.53c; Wayne Rasband, National Institutes of Health, USA).

### **Anatomical immunostaining of antennal lobes**

Following the calcium imaging experiment, the brains of drones were dissected and immediately immersed in cold 1% zinc formaldehyde in PBS (ZnFa 1% (Ott, 2008)) and kept overnight at 4°C. Brains were then washed six times in PBS (10 min each), permeabilized in PBS containing 1% Triton X-100 for 30 min, and pre-incubated 3h in PBS containing 0.3% Triton and 1% BSA (Bovine Serum Albumine in PBS, #37525, ThermoScientific). The brains were then incubated in PBS containing 0.3% Triton and 0.1% BSA with mouse monoclonal anti-SYNORF1 (DHSB, #3C11, US) at 1:100 dilution for 7 days. Brains were then washed 6 times in PBS containing 0.3% Triton and incubated in secondary antibodies directed against mouse coupled to Alexa 555 (Thermofisher, #A-21147, France) diluted at 1:200 for 5 days. Brains were then washed in PBS, dehydrated in an ascending ethanol series (30% to 100%), cleared and finally mounted in methyl salicylate (M6752, Sigma-Aldrich, France) for observation. Brains were scanned using a laser-scanning confocal microscope (Zeiss LSM 700) with a W Plan-Apochromat 20x/NA 1.0 objective using excitation wavelengths of 555 nm, and observed via a color-filtered channel around 590 nm.

### **RNA isolation and sequencing**

We pooled antennas from 15 wt and 15 *fruP1*- males (3 pools with antennas from 5 individuals each). Total RNA was isolated using Trizol, and the RNA was further purified using RNeasy MinElute Cleanup Kit (Qiagen, Hilden, Germany) as previously described (Vleurinck et al., 2016).

RNAseq (library preparation and sequencing) was conducted by the Biological and Medical Research Center (BMFZ) at the Heinrich-Heine-University Düsseldorf, Germany.

Briefly, total RNA samples were quantified (Qubit RNA HS Assay). Quality was measured by capillary electrophoresis using the Fragment Analyzer and the 'Total RNA Standard Sensitivity Assay' (Agilent Technologies). Library preparation was performed according to the manufacturer's protocol using the 'VAHTS Universal RNA-Seq Library Prep Kit for Illumina® V6 with mRNA capture module version 7.0' (Vazyme Biotech co.). 500 ng total RNA were used for mRNA capturing, fragmentation, the synthesis of cDNA, adapter ligation and library amplification. Bead-purified libraries were normalized and finally sequenced on the HiSeq 3000/4000 system (Illumina Inc.) with a read setup of SR 1x150 bp. The bcl2fastq2 tool (v2.20.0.422) was used to convert the bcl files to fastq files as well for adapter trimming and demultiplexing.

### **Bioninformatic analysis of RNA-Seq data**

Approximately 4-12 million single-end reads with a length of 150 bp were mapped to the *Apis mellifera* transcriptome (NCBI Assembly [Amel\\_HAV3.1\\_rna.fna](#)) using the kallisto software tool (Bray et al., 2016). Estimated read counts were normalized using the transcripts per kilobase million (TPM) method (Wagner et al., 2012). Differences in gene expression were calculated using DESeq2 (Love et al., 2014). Genes were differentially expressed (DEGs) if adjusted P-values (P<sub>adj</sub>) were < 0.05 (Wald test) and log<sub>2</sub> fold change was greater than 1.5.

### **Honey bee preparation for *in vivo* calcium imaging**

Eclosed mutant (*fruP1<sup>-</sup>*) and wt drones were collected, were marked, and were maintained in hives for a minimum of 8 days and a maximum 15 days. On the day of the experiment, the males were chilled on ice for 5 min just prior to the experiment until they stopped moving. Then, they were prepared following the standard preparation used to image the ventral part of the honey bee brain (Carcaud et al., 2018). Briefly, the drone was fixed in a plastic chamber with its antennae oriented to the front and the

proboscis was fixed using beeswax to avoid movement of the brain during the experiment. A pool was built with beeswax and pieces of plastic around the head capsule, and a small window was then cut in the head cuticle. Glands as well as trachea were removed to expose the brain, and the pool was filled with ringer solution (in mM: NaCl, 130; KCl, 6; MgCl<sub>2</sub>, 4; CaCl<sub>2</sub>, 5; sucrose, 160; glucose, 25; Hepes, 10; pH 6.7, 500 mOsmol; all chemicals from Sigma-Aldrich, France), to avoid desiccation of the brain surface. For staining, the saline solution was gently removed, and the brain was bathed with 20  $\mu$ L of dye solution (10  $\mu$ g Oregon Green 488 BAPTA-2 AM dissolved with 4  $\mu$ L Pluronic F-127, 20% in dimethyl sulfoxide, all from Molecular Probes, Invitrogen). The bee was left for 45 min in a humid and dark place, and then the brain was rinsed again thoroughly with saline solution in order to remove extracellular dye.

### Calcium imaging

A T.I.L.L. Photonics imaging system (Martinsried, Germany) was used to perform *in vivo* optical recordings, as described elsewhere (Haehnel et al., 2009; Carcaud et al., 2015; Carcaud et al., 2018). An epifluorescence microscope (Olympus BX51WI) was used to record activity in the AL using a 10 $\times$  water-immersion objective (Olympus, UMPlanFL; NA 0.3). Oregon Green was excited using 488 nm monochromatic light (T.I.L.L. Polychrom IV). Fluorescence light was separated by a 505 nm dichroic filter and a long-pass 515 nm emission filter and recorded with a 640  $\times$  480 pixels 12-bit monochrome CCD camera (T.I.L.L. Imago) cooled to -12°C with 4  $\times$  4 binning on chip. Each measurement consisted of 100 frames recorded at a rate of 5 Hz (integration time for each frame ~50ms).

### Odor stimuli

A constant airstream was directed from a distance of 1 cm to the drone's antennae, and odor stimuli were given at the 15<sup>th</sup> frame for 1 s. For each odor stimulus (all obtained from Sigma-Aldrich, France), 5  $\mu$ L of the solution were deposited on a filter paper inserted in a Pasteur pipette. A pipette containing a clean piece of filter paper was used as control stimulus. We tested a small set of 3 volatile odorant stimuli known

from previous work to trigger strong neural activity in workers: 1-hexanol (1-6ol), isopentyl acetate (IPA) and benzaldehyde. We also recorded responses to the major compound of the queen pheromone, 9-oxo-2-decenoic acid (9-ODA), at a concentration of 50  $\mu\text{g}/\mu\text{L}$ . As control stimulus, a pipette containing the solvent, isopropanol (iso) or a clean piece of filter paper was used. Each odorant stimulus was presented twice in a pseudo-randomized order. Only animals in which all odorants in the panel were presented were kept for analysis.

### **Calcium imaging data processing and analyses**

All analyses were carried out using custom-made software written in IDL 6.0 (Research Systems, Boulder, CO). Each odor response signal corresponds to a three-dimensional array consisting of two spatial dimensions ( $x$ - and  $y$ -coordinates) along time (100 frames). First, the relative fluorescence changes were calculated as  $\Delta F/F = (F - F_0)/F_0$  by taking as reference background  $F_0$  the average of three frames just before the odorant stimulation (frames 9-11). Possible irregularities of lamp illumination and bleaching were corrected by subtracting the median pixel value of each frame from every single pixel of the corresponding frame. Finally, the two spatial dimensions were filtered with a Gaussian filter of window size  $7 \times 7$  pixels for noise reduction. A biphasic calcium signal was observed in all recordings. For the quantification of response intensity, a mask was precisely drawn in order to exclude regions outside of the imaged structure, and the response intensity was calculated by averaging the intensity of all pixels located within the unmasked area and the two presentations of each odorant. As in previous studies using bath-applied Calcium Green (Carcaud et al., 2012), a high contrast measure for the intensity of the odor-induced response was obtained by averaging three consecutive frames at the end of the odor presentation (frames 19-21) and subtracting the average of 3 frames during the second, negative component of the signal (frames 49-51). All results are displayed as means over individuals  $\pm$  SEM.

### **Statistical analyses**

For the pairwise comparison of cells expressing Fru<sup>M</sup> in the two distinct cluster, we performed the Mann-Whitney U test in the SPSS 29 software.



Odor response intensities were compared with ANOVA for repeated measurements, using odors as within-group factors. A Dunnett post hoc test was applied to compare the intensity of the response to each stimulus with a common reference, the air control. All tests were performed with GraphPadPrism V7.00 and R ([www.r-project.org](http://www.r-project.org)).

## Supplementary data

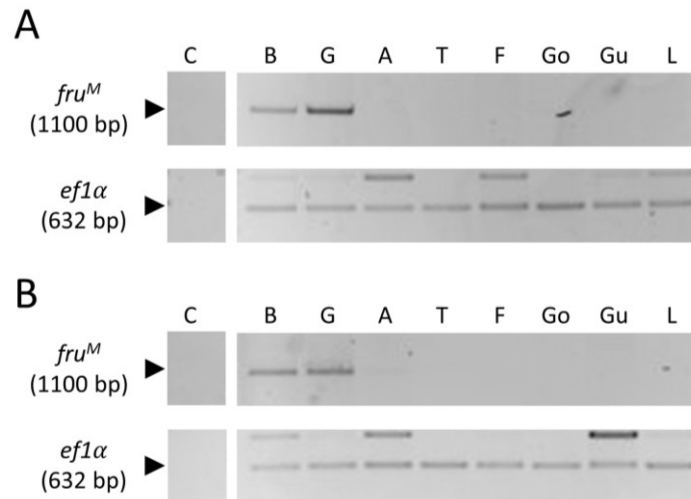

**Figure S1.** Expression of the male-specific *fruitless* transcript (*fru<sup>M</sup>*) in different tissues of adult wt males. **A+B.** Tissues of wt males were pooled (5 tissues per pool). Transcripts were amplified by RT-PCR and size resolved. PCRs were semi-quantitatively adjusted using *ef1α* gene as a control. B: brain, G: abdominal ganglia, A: antenna, T: dorsal half of thorax, F: fat body, Go: gonads, Gu: gut, L: hindlegs.

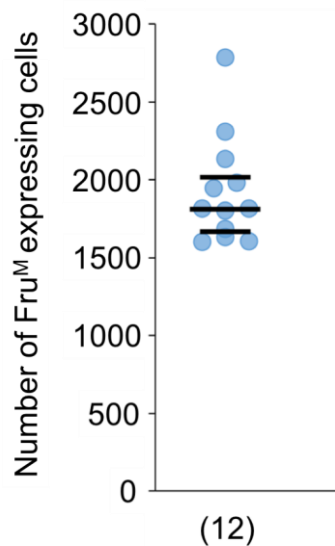

**Figure S2.** Number of *Fru<sup>M</sup>*-expressing cells in the midbrain of adult males. Number of males are shown in parentheses.

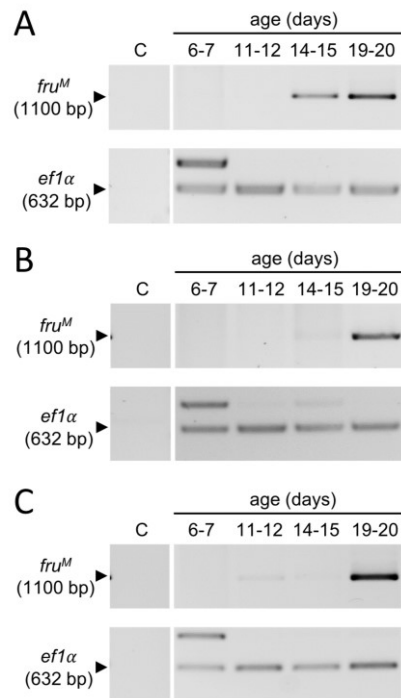

**Figure S3.** Expression of the male-specific *fruitless* transcript (*fru<sup>M</sup>*) at different developmental stages. **A-C.** Wt males of different ages were pooled (3 individuals per pool). Transcripts were amplified by RT-PCR and size resolved. PCRs were semi-quantitatively adjusted using the *ef1α* gene as a control.

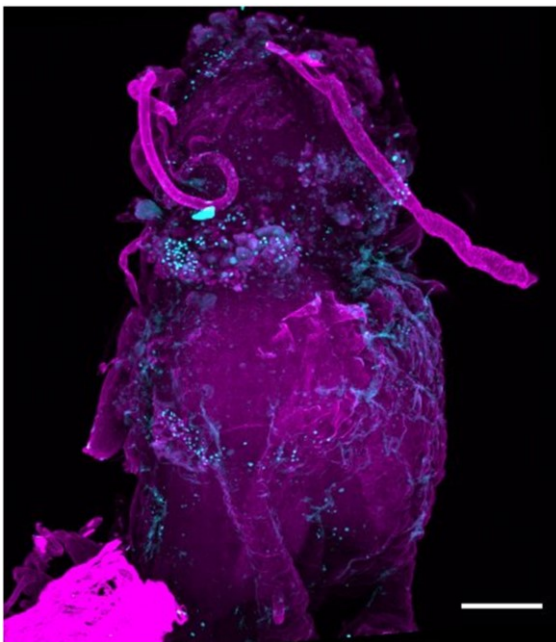

**Figure S4.** Fru<sup>M</sup> expression in the meso-metathoracic ganglion. The ganglion of an adult wt male was stained with anti-Fru (cyan) and phalloidin (F-actin, magenta). Scale 100 μm.

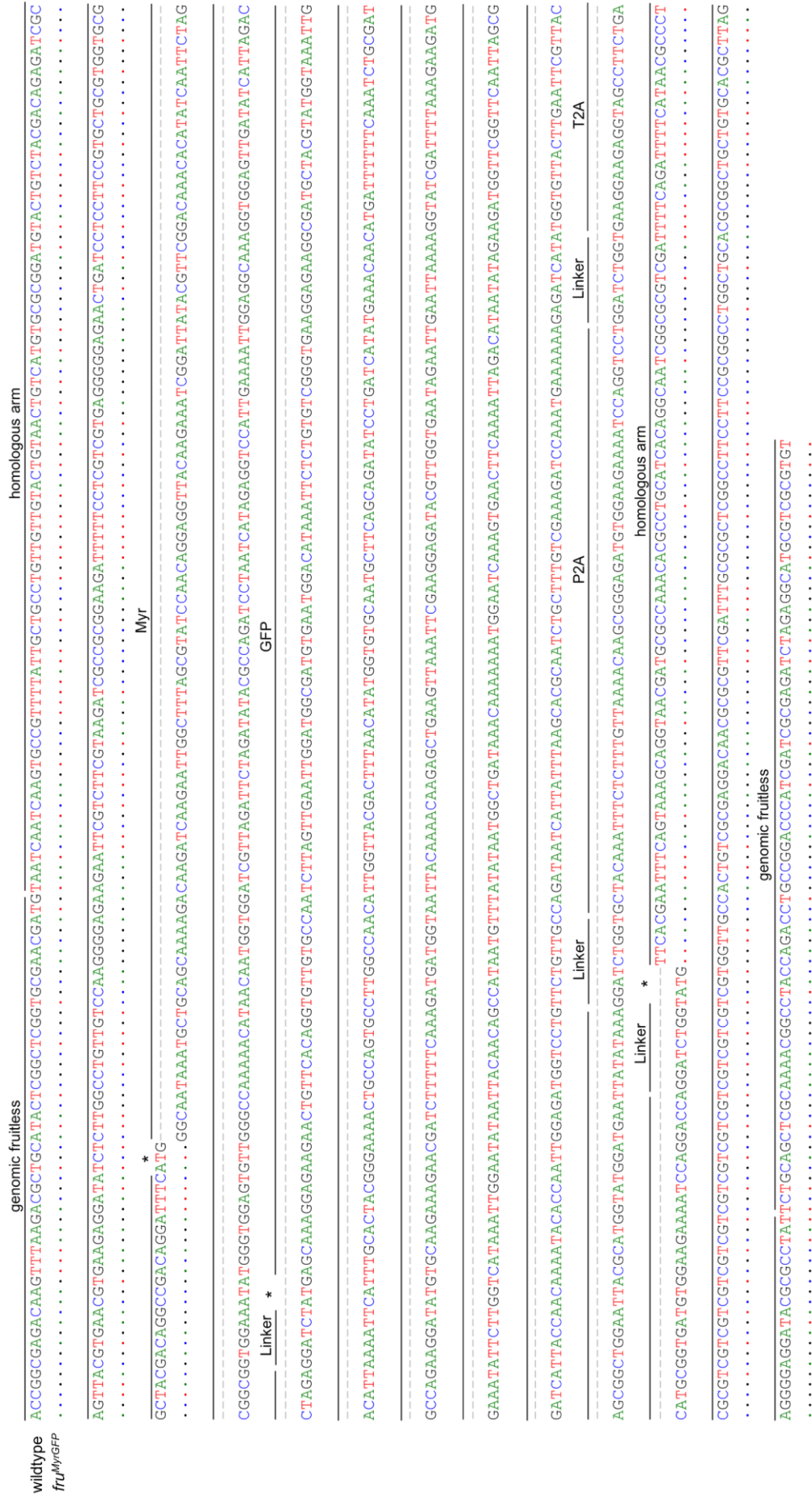

**Figure S5.** Genotype of *fru<sup>MyrGFP</sup>* mutant queens. Donor DNA was inserted into the genomic *fruitless* region by homologous directed repair. The Myr, GFP, T2A and P2A sequences were fused through linker sequences and flanked by 250 bp homologous arms. Translation start sites are indicated (\*). Wildtype sequence as a reference.

**Table S1.** Expression of Fru and GFP in cluster I in the midbrain. Anti-Fru and anti-GFP staining in adult brain were analyzed. Association between anti-Fru and anti-GFP staining in different individuals.

specimen	Number of cells expressing Fru	Number of cells expressing GFP	Percentage of cells expressing Fru and GFP
A1	69	69	100
A2	76	76	100
A3	81	81	100
A4	73	73	100
A5	89	89	100
A6	84	84	100

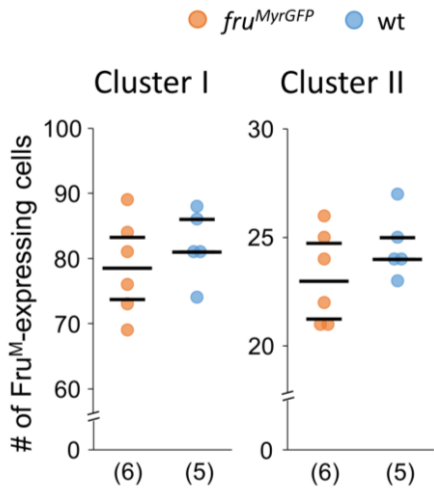

**Fig. S6.** Comparison of Fru<sup>M</sup>-expressing cells in clusters I and II of wt and *fru<sup>MyrGFP</sup>* males.

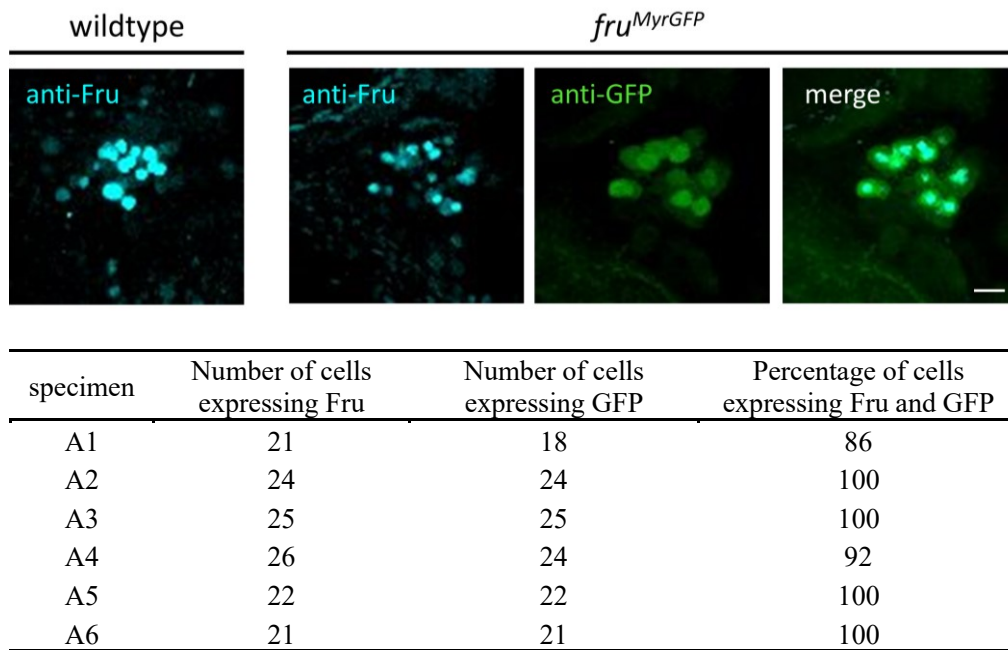

**Figure S7.** Expression of Fru and GFP in Cluster II. Adult male brains were stained with anti-Fru (cyan) and anti-GFP (green). Scale 10  $\mu$ m. Table: Association between anti-Fru and anti-GFP staining in different individuals.

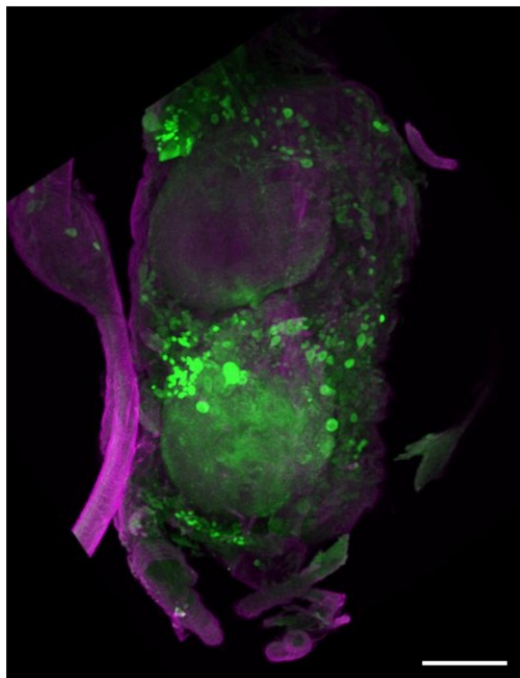

**Figure S8.** GFP expression in the meso-metathoracic ganglion. The ganglion of an adult *fru*<sup>MyrGFP</sup> male was stained with anti-GFP (green) and phalloidin (f-actin, magenta). Scale 100  $\mu$ m.

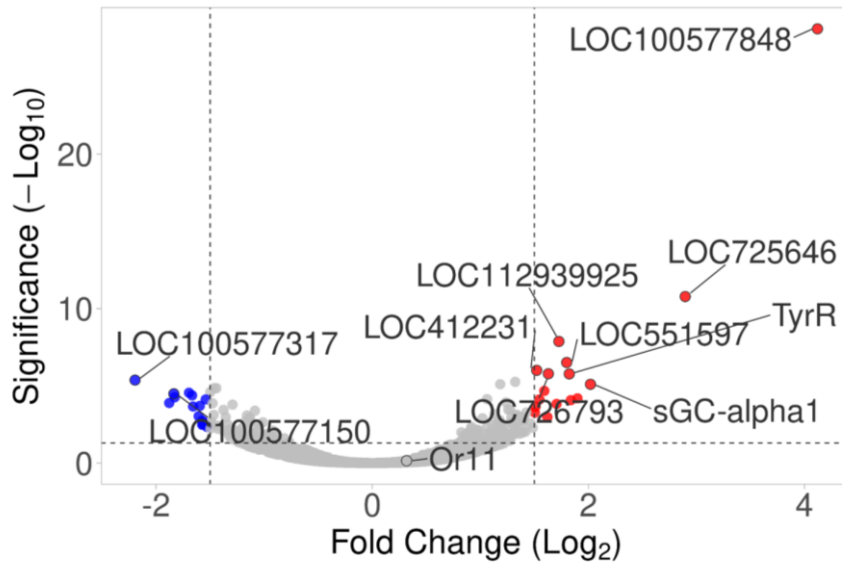

**Figure S9.** Overall differences between the antennal transcriptome of wt (n=3) and *fruP1*<sup>-</sup> males (n=3). Genes with negative log<sub>2</sub> fold-change values (left) were more highly expressed in wt males, and genes with positive log<sub>2</sub> fold-change values (right) were more highly expressed in *fruP1*<sup>-</sup> males. Red and blue circles indicate genes with significantly different expression (adjusted P-value,  $P_{adj} < 0.05$ , Wald test, DESeq2 and a log<sub>2</sub> (fold change) value  $\geq 1.5$ ). The top 10 differentially expressed genes and Or11 are shown.

**Table S2.** Nucleotide sequences of used primers.

Name	Sequence (5' to 3')
SK23	GTAGGCCGTTTTGCGAGCTG
SK27	GTCTCACGTTTCGGTGGTGGT
SK29	TTCCCGAATCGACGTAAGTGTGC
SK54	CAATCAAGTGCCGTTTTATTGCTG
SK55	CTGCGATGCCAGAAGGATATGTG
SK56	CACATATCCTTCTGGCATCGCAG
SK60	AACTGATCCTCCTCCGTGCTGCG
SK61	AGTGGTTCCTGATGTGCGTCACGA
Ef1	GATATCGCCCTGTGGAAGTTC
Ef2	GCTGCTGGAGCGAATGTTAC

## References

- Abel, R., Rybak, J., Menzel, R., and R Abel, J.R., R Menzel (2001). Structure and response patterns of olfactory interneurons in the honeybee, *Apis mellifera*. *Journal of Comparative Neurology*, 437, 363-383.
- Arnold, G., Budharugsa, S., and Masson, C. (1988). Organization of the antennal lobe in the queen honey bee, *Apis mellifera* L. (Hymenoptera : Apidae). *International Journal of Insect Morphology and Embryology*, 17, 185-195.
- Arnold, G., Masson, C., and Budharugsa, S. (1985). Comparative study of the antennal lobes and their afferent pathway in the worker bee and the drone (*Apis mellifera*). *Cell and Tissue Research*, 242, 593-605.
- Arthur, B.I., Jr., Jallon, J.M., Caflisch, B., Choffat, Y., and Nöthiger, R. (1998). Sexual behaviour in *Drosophila* is irreversibly programmed during a critical period. *Curr Biol*, 8, 1187-1190.
- Basrur, N.S., De Obaldia, M.E., Morita, T., Herre, M., von Heynitz, R.K., Tsitohay, Y.N., and Vosshall, L.B. (2020). Fruitless mutant male mosquitoes gain attraction to human odor. *Elife*, 9, e63982.
- Bastin, F., Couto, A., Larcher, V., Phiancharoen, M., Koeniger, G., Koeniger, N., and Sandoz, J.C. (2018). Marked interspecific differences in the neuroanatomy of the male olfactory system of honey bees (genus *Apis*). *J Comp Neurol*, 526, 3020-3034.
- Blut, C., Crespi, A., Mersch, D., Keller, L., Zhao, L., Kollmann, M., Schellscheidt, B., Fulber, C., and Beye, M. (2017). Automated computer-based detection of encounter behaviours in groups of honeybees. *Sci Rep*, 7, 17663.
- Brandstaetter, A.S., Bastin, F., and Sandoz, J.C. (2014). Honeybee drones are attracted by groups of conspecifics in a walking simulator. *Journal of Experimental Biology*, 217, 1278-1285.
- Bray, N.L., Pimentel, H., Melsted, P., and Pachter, L. (2016). Near-optimal probabilistic RNA-seq quantification. *Nature biotechnology*, 34, 525-527.
- Brockmann, A., and Brückner, D. (1999). Dimorphic antennal systems in gynandromorphic honey bees, *Apis Mellifera* L. (Hymenoptera: Apidae). *International Journal of Insect Morphology and Embryology*, 28, 53-60.
- Brockmann, A., and Brückner, D. (2001). Structural differences in the drone olfactory system of two phylogenetically distant *Apis* species, *A. florea* and *A. mellifera*. *Naturwissenschaften*, 88, 78-81.
- Brockmann, A., Dietz, D., Spaethe, J., and Tautz, J. (2006). Beyond 9-ODA: sex pheromone communication in the European honey bee *Apis mellifera* L. *Journal of chemical ecology*, 32, 657-667.
- Camara, N., Whitworth, C., Dove, A., and Van Doren, M. (2019). Doublesex controls specification and maintenance of the gonad stem cell niches in *Drosophila*. *Development*, 146, dev170001.
- Carcaud, J., Giurfa, M., and Sandoz, J.C. (2015). Differential combinatorial coding of pheromones in two olfactory subsystems of the honey bee brain. *J Neurosci*, 35, 4157-4167.
- Carcaud, J., Giurfa, M., and Sandoz, J.C. (2018). Differential Processing by Two Olfactory Subsystems in the Honeybee Brain. *Neuroscience*, 374, 33-48.
- Carcaud, J., Hill, T., Giurfa, M., and Sandoz, J.C. (2012). Differential coding by two olfactory subsystems in the honeybee brain. *J Neurophysiol*, 108, 1106-1121.
- Demir, E., and Dickson, B.J. (2005). fruitless Splicing Specifies Male Courtship Behavior in *Drosophila*. *Cell*, 121, 785-794.



- Donnelly, M.L.L., Luke, G., Mehrotra, A., Li, X., Hughes, L.E., Gani, D., and Ryan, M.D. (2001). Analysis of the aphthovirus 2A/2B polyprotein 'cleavage' mechanism indicates not a proteolytic reaction, but a novel translational effect: a putative ribosomal 'skip'. *J Gen Virol*, 82, 1013-1025.
- Free, J.B. (1957). The transmission of food between worker honeybees. *Br J Anim Behav*, 5, 41-47.
- Galizia, C.G., and Menzel, R. (2000). Odour perception in honeybees: coding information in glomerular patterns. *Current Opinion in Neurobiology*, 10, 504-510.
- Galizia, C.G., and Menzel, R. (2001). The role of glomeruli in the neural representation of odours: results from optical recording studies. *J Insect Physiol*, 47, 115-130.
- Gary, N.E. (1962). Chemical Mating Attractants in the Queen Honey Bee. *Science (New York, N.Y.)*, 136, 773-774.
- Gernat, T., Rao, V.D., Middendorf, M., Dankowicz, H., Goldenfeld, N., and Robinson, G.E. (2018). Automated monitoring of behavior reveals bursty interaction patterns and rapid spreading dynamics in honeybee social networks. *Proc Natl Acad Sci U S A*, 115, 1433-1438.
- Groh, C., Ahrens, D., and Rössler, W. (2006). Environment- and Age-Dependent Plasticity of Synaptic Complexes in the Mushroom Bodies of Honeybee Queens. *Brain, Behavior and Evolution*, 68, 1-14.
- Groh, C., and Rössler, W. (2008). Caste-specific postembryonic development of primary and secondary olfactory centers in the female honeybee brain. *Arthropod Struct Dev*, 37, 459-468.
- Gronenberg, W. (1986). Physiological and anatomical properties of optical input-fibres to the mushroom body in the bee brain. *Journal of Insect Physiology*, 32, 695-704.
- Gronenberg, W. (2001). Subdivisions of hymenopteran mushroom body calyces by their afferent supply. *Journal of Comparative Neurology*, 435, 474-489.
- Haehnel, M., Froese, A., and Menzel, R. (2009). In vivo Ca<sup>2+</sup> imaging of mushroom body neurons during olfactory learning in the honey bee. *J Vis Exp*, e1353.
- Hasselmann, M., and Beye, M. (2004). Signatures of selection among sex-determining alleles of the honey bee. *Proceedings of the National Academy of Sciences of the United States of America*, 101, 4888-4893.
- Jinek, M., Chylinski, K., Fonfara, I., Hauer, M., Doudna, J.A., and Charpentier, E. (2012). A programmable dual-RNA-guided DNA endonuclease in adaptive bacterial immunity. *Science (New York, N.Y.)*, 337, 816-821.
- Kimura, K., Hachiya, T., Koganezawa, M., Tazawa, T., and Yamamoto, D. (2008). Fruitless and doublesex coordinate to generate male-specific neurons that can initiate courtship. *Neuron*, 59, 759-769.
- Kimura, K.I., Ote, M., Tazawa, T., and Yamamoto, D. (2005). Fruitless specifies sexually dimorphic neural circuitry in the Drosophila brain. *Nature*, 438, 229-233.
- Koeniger G, K.N., Ellis J, Connor L J (2014). Mating biology of honey bees (*Apis mellifera*).
- Köhnen, S., Müller, M., Ulbricht, P., Eltz, T., and Beye, M. (2023). fruitless specifies male group-living behaviors in the honeybee *Apis mellifera*.
- Kropf, J., Kelber, C., Bieringer, K., and Rössler, W. (2014). Olfactory subsystems in the honeybee: sensory supply and sex specificity. *Cell Tissue Res*, 357, 583-595.

- Kyrou, K., Hammond, A.M., Galizi, R., Kranjc, N., Burt, A., Beaghton, A.K., Nolan, T., and Crisanti, A. (2018). A CRISPR–Cas9 gene drive targeting doublesex causes complete population suppression in caged *Anopheles gambiae* mosquitoes. *Nature Biotechnology*, 36, 1062-1066.
- Lazareva, A.A., Roman, G., Mattox, W., Hardin, P.E., and Dauwalder, B. (2007). A role for the adult fat body in *Drosophila* male courtship behavior. *PLoS genetics*, 3, e16.
- Lee, G., Foss, M., Goodwin, S.F., Carlo, T., Taylor, B.J., and Hall, J.C. (2000). Spatial, Temporal, and Sexually Dimorphic Expression Patterns of the fruitless Gene in the *Drosophila* Central Nervous System. *J Neurobiol*, 43, 404-426.
- Love, M.I., Huber, W., and Anders, S. (2014). Moderated estimation of fold change and dispersion for RNA-seq data with DESeq2. *Genome Biology*, 15, 1-21.
- Mariette, J., Carcaud, J., and Sandoz, J.C. (2021). The neuroethology of olfactory sex communication in the honeybee *Apis mellifera* L. *Cell and Tissue Research*, 383, 177-194.
- Menzel, R. (2012). The honeybee as a model for understanding the basis of cognition. *Nature Reviews Neuroscience*, 13, 758-768.
- Mobbs, P.G. (1984). Neural networks in the mushroom bodies of the honeybee. *Journal of Insect Physiology*, 30, 43-58.
- Mota, T., Yamagata, N., Giurfa, M., Gronenberg, W., and Sandoz, J.C. (2011). Neural organization and visual processing in the anterior optic tubercle of the honeybee brain. *J Neurosci*, 31, 11443-11456.
- Mysore, K., Sun, L., Tomchaney, M., Sullivan, G., Adams, H., Piscocoy, A.S., Severson, D.W., Syed, Z., and Duman-Scheel, M. (2015). siRNA-Mediated Silencing of doublesex during Female Development of the Dengue Vector Mosquito *Aedes aegypti*. *PLoS Negl Trop Dis*, 9, e0004213.
- Netschitailo, O., Wang, Y., Wagner, A., Sommer, V., Verhulst, E.C., and Beye, M. (2023). The function and evolution of a genetic switch controlling sexually dimorphic eye differentiation in honeybees. *Nat Commun*, 14, 463.
- Nishino, H., Nishikawa, M., Mizunami, M., and Yokohari, F. (2009). Functional and topographic segregation of glomeruli revealed by local staining of antennal sensory neurons in the honeybee *Apis mellifera*. *J Comp Neurol*, 515, 161-180.
- Ohtani, T. (1974). Behavior Repertoire of Adult Drone Honeybee within Observation Hives. *Jour. Fac. Sci. Hokkaido Univ. Ser. VI, Zool*, 19, 706-721.
- Ott, S.R. (2008). Confocal microscopy in large insect brains: zinc-formaldehyde fixation improves synapsin immunostaining and preservation of morphology in whole-mounts. *J Neurosci Methods*, 172, 220-230.
- Rideout, E.J., Billeter, J.C., and Goodwin, S.F. (2007). The sex-determination genes fruitless and doublesex specify a neural substrate required for courtship song. *Curr Biol*, 17, 1473-1478.
- Roth, A., Vleurinck, C., Netschitailo, O., Bauer, V., Otte, M., Kaftanoglu, O., Page, R.E., and Beye, M. (2019). A genetic switch for worker nutrition-mediated traits in honeybees. *PLOS Biology*, 17, e3000171.
- Ruta, V., Datta, S.R., Vasconcelos, M.L., Freeland, J., Looger, L.L., and Axel, R. (2010). A dimorphic pheromone circuit in *Drosophila* from sensory input to descending output. *Nature* 2010 468:7324, 468, 686-690.
- Rybak, J., and Menzel, R. (1993). Anatomy of the mushroom bodies in the honey bee brain: the neuronal connections of the alpha-lobe. *J Comp Neurol*, 334, 444-465.

- Ryner, L.C., Goodwin, S.F., Castrillon, D.H., Anand, A., Villella, A., Baker, B.S., Hall, J.C., Taylor, B.J., and Wasserman, S.A. (1996). Control of male sexual behavior and sexual orientation in *Drosophila* by the fruitless gene. *Cell*, 87, 1079-1089.
- Sandoz, J.C. (2006). Odour-evoked responses to queen pheromone components and to plant odours using optical imaging in the antennal lobe of the honey bee drone *Apis mellifera* L. *Journal of Experimental Biology*, 209, 3587-3598.
- Sandoz, J.C. (2011). Behavioral and neurophysiological study of olfactory perception and learning in honeybees. *Front Syst Neurosci*, 5, 98.
- Sandoz, J.C., Deisig, N., de Brito Sanchez, M.G., and Giurfa, M. (2007). Understanding the logics of pheromone processing in the honeybee brain: From labeled-lines to across-fiber patterns. *Frontiers in Behavioral Neuroscience*, 1, .
- Schröter, U., and Malun, D. (2000). Formation of antennal lobe and mushroom body neuropils during metamorphosis in the honeybee, *Apis mellifera*. *J Comp Neurol*, 422, 229-245.
- Schulte, C., Theilenberg, E., Müller-Borg, M., Gempe, T., and Beye, M. (2014). Highly efficient integration and expression of piggyBac-derived cassettes in the honeybee (*Apis mellifera*). *Proc Natl Acad Sci U S A*, 111, 9003-9008.
- Seeley, T.D. (1995). The wisdom of the hive : the social physiology of honey bee colonies. *Harvard University Press*.
- Sharma, P., Yan, F., Doronina, V.A., Escuin-Ordinas, H., Ryan, M.D., and Brown, J.D. (2012). 2A peptides provide distinct solutions to driving stop-carry on translational recoding. *Nucleic Acids Res*, 40, 3143-3151.
- Smith, M.L., Davidson, J.D., Wild, B., Dormagen, D.M., Landgraf, T., and Couzin, I.D. (2022). Behavioral variation across the days and lives of honey bees. *iScience*, 25, 104842.
- Strausfeld, N.J. (2002). Organization of the honey bee mushroom body: Representation of the calyx within the vertical and gamma lobes. *Journal of Comparative Neurology*, 450, 4-33.
- Strutz, A., Soelter, J., Baschwitz, A., Farhan, A., Grabe, V., Rybak, J., Knaden, M., Schmuker, M., Hansson, B.S., and Sachse, S. (2014). Decoding odor quality and intensity in the *Drosophila* brain. *eLife*, 3, e04147.
- Szymczak-Workman, A.L., Vignali, K.M., and Vignali, D.A. (2012). Design and construction of 2A peptide-linked multicistronic vectors. *Cold Spring Harb Protoc*, 2012, 199-204.
- Tissot, M., and Stocker, R.F. (2000). Metamorphosis in *Drosophila* and other insects: the fate of neurons throughout the stages. *Prog Neurobiol*, 62, 89-111.
- Vleurinck, C., Raub, S., Sturgill, D., Oliver, B., and Beye, M. (2016). Linking genes and brain development of honeybee workers: A Whole-Transcriptome approach. *PLoS ONE*, 11, e0157980.
- Wagner, A., Seiler, J., and Beye, M. (2022). Highly efficient site-specific integration of DNA fragments into the honeybee genome using CRISPR/Cas9. *G3*, 12, jkac098.
- Wagner, G.P., Kin, K., and Lynch, V.J. (2012). Measurement of mRNA abundance using RNA-seq data: RPKM measure is inconsistent among samples. *Theory Biosci*, 131, 281-285.
- Wanner, K.W., Nichols, A.S., Walden, K.K.O., Brockmann, A., Luetje, C.W., and Robertson, H.M. (2007). A honey bee odorant receptor for the queen substance 9-oxo-2-decenoic acid. *Proceedings of the National Academy of Sciences of the United States of America*, 104, 14383-14388.

- Ward, A.J.W., and Webster, M. (2016). *Sociality: The Behaviour of Group-Living Animals*. (Springer, Cham, 2016).
- Wilson, E.O. (2000). *Sociobiology: The New Synthesis*. *Harvard University Press*.
- Winston, M.L. (1987). *The biology of the honey bee*. *Harvard University Press*.
- Xu, J., Liu, W., Yang, D., Chen, S., Chen, K., Liu, Z., Yang, X., Meng, J., Zhu, G., Dong, S., et al. (2020). Regulation of olfactory-based sex behaviors in the silkworm by genes in the sex-determination cascade. *PLOS Genetics*, 16, e1008622.
- Xu, J., Zhan, S., Chen, S., Zeng, B., Li, Z., James, A.A., Tan, A., and Huang, Y. (2017). Sexually dimorphic traits in the silkworm, *Bombyx mori*, are regulated by doublesex. *Insect Biochem Mol Biol*, 80, 42-51.
- Zhuo, J.C., Hu, Q.L., Zhang, H.H., Zhang, M.Q., Jo, S.B., and Zhang, C.X. (2018). Identification and functional analysis of the doublesex gene in the sexual development of a hemimetabolous insect, the brown planthopper. *Insect Biochem Mol Biol*, 102, 31-42.

## Author's Contribution: Manuscript II

### The gene *fruitless* acts in a subset of the CNS to specify male social behaviors in honeybees

Journal: Manuscript in preparation for submission to "Nature Communications"

Sven Köhnen, Julie Carcaud, Pia Ulbricht, Jean-Christophe Sandoz and Martin Beye

1<sup>st</sup> author

Author's contributions:

- Concept of study
- Experimental design
- sgRNA and donor DNA synthesis
- Implementation of microinjections (*fruP1*<sup>-</sup> males)
- Collection and preparation of samples for antennal transcriptome analysis
- Immunohistochemistry and microscope imaging
- Data analyses: sequencing data, statistics
- Bioinformatic analysis of raw RNASeq data
- Evaluation of processed data
- Authoring the manuscript

## **Kapitel III**

## Zusammenfassung

Soziale Verhaltensweisen sind für das Überleben und den Erfolg sozialer Verbände von entscheidender Bedeutung, ihre molekularen Grundlagen sind jedoch weitgehend unbekannt. Die Honigbiene *A. mellifera* gilt vor allem wegen des großen Verhaltensrepertoires der sterilen Arbeiterinnen als Modellorganismus für soziales Verhalten. Aber auch die männlichen Drohnen sind an das Leben in einem sozialen Umfeld angepasst. Ihre Interaktionen mit den Arbeiterinnen stellen die auffälligste dieser Anpassungen dar. Im Rahmen dieser Arbeit konnte nachgewiesen werden, dass das Gen *fruitless (fru)* an der Spezifizierung dieser sozialen Verhaltensweisen in männlichen Honigbienen beteiligt ist. Der Transkriptionsfaktor *fru* ist essentiell für das Paarungsverhalten männlicher Fruchtfliegen, und auch beim Seidenspinner und der Gelbfiebermücke konnte ein Einfluss auf das männliche Verhalten nachgewiesen werden. Die Struktur von *fru* ist darüber hinaus in weiteren Insektenarten konserviert. Es konnte gezeigt werden, dass das Transkript des Promotors P1 geschlechtsspezifisch gespleißt wird und nur die männliche Variante (*fru<sup>M</sup>*) für ein funktionales Protein kodiert. Mit Hilfe des CRISPR/Cas9-Systems wurde die P1-Promotorregion deletiert und anschließend das Verhalten der mutierten Drohnen in einer kleinen Kolonie analysiert. Die mutierten Drohnen initiierten signifikant weniger Interaktionen mit Arbeiterinnen als wildtypische Drohnen. Sie bettelten seltener und wurden seltener von Arbeiterinnen gefüttert, was zeigt, dass *fru<sup>M</sup>* wesentliche Aspekte dieser Verhaltensweisen spezifiziert. Außerdem war die Reaktion der mutierten Drohnen auf das Sexualpheromon 9-ODA signifikant verändert. Dies impliziert, dass *fru<sup>M</sup>* auch an der Spezifizierung von Aspekten des Paarungsverhaltens beteiligt ist. Die Expression der Genprodukte von *fru<sup>M</sup>* im Gehirn und in den thorakalen und abdominalen Ganglien zeigt, dass die Voraussetzungen für diese Verhaltensweisen während der Entwicklung im zentralen Nervensystem geschaffen werden. Da das Fru<sup>M</sup> Protein ausschließlich im Zellkern exprimiert ist, wurden die Projektionsmuster der Fru<sup>M</sup>-exprimierenden Zellen im Gehirn in einem weiteren experimentellen Ansatz analysiert. Dazu wurde membrangebundenes GFP unter Kontrolle des endogenen Promotors P1 exprimiert. Anhand der GFP-Expression konnte gezeigt werden, dass Neuronen, die Fru<sup>M</sup> exprimieren, an der Verarbeitung verschiedener Sinnesmodalitäten wie Riechen, Sehen und Schmecken beteiligt sind. Darüber hinaus ist Fru<sup>M</sup> in Neuronen höherer Verarbeitungszentren wie den Pilzkörpern und dem lateralen Horn exprimiert.

Insgesamt konnte im Rahmen dieser Arbeit nachgewiesen werden, dass ein einzelnes, konserviertes Gen, *fruitless*, für die Spezifizierung wichtiger Aspekte sozialer Verhaltensweisen verantwortlich ist und somit im Laufe der Evolution eine zusätzliche Funktion erlangt hat. Diese Ergebnisse stellen einen wichtigen Schritt zum besseren Verständnis der molekularen Grundlagen sozialen Verhaltens dar.



## Literaturverzeichnis

- Abel, R., Rybak, J., and Menzel, R. (2001). Structure and response patterns of olfactory interneurons in the honeybee, *Apis mellifera*. *Journal of Comparative Neurology*, 437, 363-383.
- Albers, H.E. (2012). The regulation of social recognition, social communication and aggression: vasopressin in the social behavior neural network. *Horm Behav*, 61, 283-292.
- Anand, A., Vilella, A., Ryner, L.C., Carlo, T., Goodwin, S.F., Song, H.J., Gailey, D.A., Morales, A., Hall, J.C., Baker, B.S., and Taylor, B.J. (2001). Molecular genetic dissection of the sex-specific and vital functions of the *Drosophila melanogaster* sex determination gene *fruitless*. *Genetics*, 158, 1569.
- Arnold, G., Masson, C., and Budharugsa, S. (1985). Comparative study of the antennal lobes and their afferent pathway in the worker bee and the drone (*Apis mellifera*). *Cell and Tissue Research*, 242, 593-605.
- Balter, M. (2012). Why Are Our Brains So Big? *Science*, 338, 33-34.
- Basrur, N.S., De Obaldia, M.E., Morita, T., Herre, M., von Heynitz, R.K., Tsitohay, Y.N., and Vosshall, L.B. (2020). *Fruitless* mutant male mosquitoes gain attraction to human odor. *Elife*, 9, e63982.
- Bastin, F., Couto, A., Larcher, V., Phiancharoen, M., Koeniger, G., Koeniger, N., and Sandoz, J.C. (2018). Marked interspecific differences in the neuroanatomy of the male olfactory system of honey bees (genus *Apis*). *J Comp Neurol*, 526, 3020-3034.
- Bastin, F., Savarit, F., Lafon, G., and Sandoz, J.-C. (2017). Age-specific olfactory attraction between Western honey bee drones (*Apis mellifera*) and its chemical basis. *PLOS ONE*, 12, e0185949.
- Baudry, E., Solignac, M., Garnery, L., Gries, M., Cornuet, J.M., and Koeniger, N. (1998). Relatedness among honeybees (*Apis mellifera*) of a drone congregation. *Proceedings of the Royal Society B: Biological Sciences*, 265, 2009.
- Benson-Amram, S., Dantzer, B., Stricker, G., Swanson, E.M., and Holekamp, K.E. (2016). Brain size predicts problem-solving ability in mammalian carnivores. *Proc Natl Acad Sci U S A*, 113, 2532-2537.
- Bertossa, R.C., van de Zande, L., and Beukeboom, L.W. (2009). The *Fruitless* gene in *Nasonia* displays complex sex-specific splicing and contains new zinc finger domains. *Mol Biol Evol*, 26, 1557-1569.
- Beye, M., Hasselmann, M., Fondrk, M.K., Page, R.E., and Omholt, S.W. (2003). The gene *csd* is the primary signal for sexual development in the honeybee and encodes an SR-type protein. *Cell*, 114, 419-429.
- Boucher, M., and Schneider, S.S. (2009). Communication signals used in worker–drone interactions in the honeybee, *Apis mellifera*. *Animal Behaviour*, 78, 247-254.
- Brandstaetter, A.S., Bastin, F., and Sandoz, J.C. (2014). Honeybee drones are attracted by groups of conspecifics in a walking simulator. *Journal of Experimental Biology*, 217, 1278-1285.
- Brockmann, A., and Brückner, D. (1999). Dimorphic antennal systems in gynandromorphic honey bees, *Apis Mellifera* L. (Hymenoptera: Apidae). *International Journal of Insect Morphology and Embryology*, 28, 53-60.

- Brockmann, A., and Brückner, D. (2001). Structural differences in the drone olfactory system of two phylogenetically distant *Apis* species, *A. florea* and *A. mellifera*. *Naturwissenschaften*, 88, 78-81.
- Brockmann, A., Dietz, D., Spaethe, J., and Tautz, J. (2006). Beyond 9-ODA: sex pheromone communication in the European honey bee *Apis mellifera* L. *Journal of chemical ecology*, 32, 657-667.
- Butler, C.G., Callow, R.K., and Johnston, N.C. (1959). Extraction and Purification of 'Queen Substance' from Queen Bees. *Nature* 1959 184:4702, 184, 1871-1871.
- Camara, N., Whitworth, C., Dove, A., and Van Doren, M. (2019). Doublesex controls specification and maintenance of the gonad stem cell niches in *Drosophila*. *Development*, 146, dev170001.
- Chiang, A.S., Lin, C.Y., Chuang, C.C., Chang, H.M., Hsieh, C.H., Yeh, C.W., Shih, C.T., Wu, J.J., Wang, G.T., Chen, Y.C., et al. (2011). Three-dimensional reconstruction of brain-wide wiring networks in *Drosophila* at single-cell resolution. *Curr Biol*, 21, 1-11.
- Clyne, P.J., Warr, C.G., and Carlson, J.R. (2000). Candidate taste receptors in *Drosophila*. *Science*, 287, 1830-1834.
- Clyne, P.J., Warr, C.G., Freeman, M.R., Lessing, D., Kim, J., and Carlson, J.R. (1999). A novel family of divergent seven-transmembrane proteins: candidate odorant receptors in *Drosophila*. *Neuron*, 22, 327-338.
- de Brito Sanchez, M.G. (2011). Taste perception in honey bees. *Chem Senses*, 36, 675-692.
- Demir, E., and Dickson, B.J. (2005). fruitless Splicing Specifies Male Courtship Behavior in *Drosophila*. *Cell*, 121, 785-794.
- Devi, T.R., and Shyamala, B.V. (2013). Male- and female-specific variants of doublesex gene products have different roles to play towards regulation of Sex combs reduced expression and sex comb morphogenesis in *Drosophila*. *J Biosci*, 38, 455-460.
- Dolan, M.-J., Frechter, S., Bates, A.S., Dan, C., Huoviala, P., Roberts, R.J.V., Schlegel, P., Dhawan, S., Tabano, R., Dionne, H., et al. (2019). Neurogenetic dissection of the *Drosophila* lateral horn reveals major outputs, diverse behavioural functions, and interactions with the mushroom body. *eLife*, 8, e43079.
- Dornan, A.J., Gailey, D.A., and Goodwin, S.F. (2005). GAL4 enhancer trap targeting of the *Drosophila* sex determination gene fruitless. *Genesis (New York, N.Y. : 2000)*, 42, 236-246.
- Dunbar, R.I. (2009). The social brain hypothesis and its implications for social evolution. *Ann Hum Biol*, 36, 562-572.
- Dunbar, R.I.M. (1998). The social brain hypothesis. *Evolutionary Anthropology: Issues, News, and Reviews*, 6, 178-190.
- Dunipace, L., Meister, S., McNealy, C., and Amrein, H. (2001). Spatially restricted expression of candidate taste receptors in the *Drosophila* gustatory system. *Curr Biol*, 11, 822-835.
- Farris, S.M. (2016). Insect societies and the social brain. *Curr Opin Insect Sci*, 15, 1-8.
- Flanagan, D., and Mercer, A.R. (1989). An atlas and 3-D reconstruction of the antennal lobes in the worker honey bee, *Apis mellifera* L. (Hymenoptera : Apidae). *International Journal of Insect Morphology and Embryology*, 18, 145-159.

- Fox, A.N., Pitts, R.J., Robertson, H.M., Carlson, J.R., and Zwiebel, L.J. (2001). Candidate odorant receptors from the malaria vector mosquito *Anopheles gambiae* and evidence of down-regulation in response to blood feeding. *Proc Natl Acad Sci U S A*, 98, 14693-14697.
- Free, J.B. (1957). The food of adult drone honeybees (*Apis mellifera*). *The British Journal of Animal Behaviour*, 5, 7-11.
- Gailey, D.A., Billeter, J.C., Liu, J.H., Bauzon, F., Allendorfer, J.B., and Goodwin, S.F. (2006). Functional conservation of the fruitless male sex-determination gene across 250 Myr of insect evolution. *Mol. Biol. Evol.*, 23, 633-643.
- Galizia, C.G., and Kimmerle, B. (2004). Physiological and morphological characterization of honeybee olfactory neurons combining electrophysiology, calcium imaging and confocal microscopy. *J Comp Physiol A Neuroethol Sens Neural Behav Physiol*, 190, 21-38.
- Galizia, C.G., Sachse, S., Rappert, A., and Menzel, R. (1999). The glomerular code for odor representation is species specific in the honeybee *Apis mellifera*. *Nat Neurosci*, 2, 473-478.
- Gao, Q., and Chess, A. (1999). Identification of candidate *Drosophila* olfactory receptors from genomic DNA sequence. *Genomics*, 60, 31-39.
- Gary, N.E. (1962). Chemical Mating Attractants in the Queen Honey Bee. *Science (New York, N.Y.)*, 136, 773-774.
- Gempe, T., Hasselmann, M., Schiøtt, M., Hause, G., Otte, M., and Beye, M. (2009). Sex determination in honeybees: two separate mechanisms induce and maintain the female pathway. *PLoS biology*, 7, e1000222.
- Hansson, B.S., Christensen, T.A., and Hildebrand, J.G. (1991). Functionally distinct subdivisions of the macroglomerular complex in the antennal lobe of the male sphinx moth *Manduca sexta*. *Journal of comparative Neurology*, 312, 264-278.
- Hasselmann, M., Gempe, T., Schiott, M., Nunes-Silva, C.G., Otte, M., and Beye, M. (2008). Evidence for the evolutionary nascence of a novel sex determination pathway in honeybees. *Nature*, 454, 519-522.
- Heinrichs, V., Ryner, L.C., and Baker, B.S. (1998). Regulation of sex-specific selection of fruitless 5' splice sites by transformer and transformer-2. *Molecular and cellular biology*, 18, 450-458.
- Heyes, C. (2012). What's social about social learning? *J Comp Psychol*, 126, 193-202.
- Hill, C.A., Fox, A.N., Pitts, R.J., Kent, L.B., Tan, P.L., Chrystal, M.A., Cravchik, A., Collins, F.H., Robertson, H.M., and Zwiebel, L.J. (2002). G protein-coupled receptors in *Anopheles gambiae*. *Science*, 298, 176-178.
- Hourcade, B., Muenz, T.S., Sandoz, J.C., Rössler, W., and Devaud, J.M. (2010). Long-term memory leads to synaptic reorganization in the mushroom bodies: a memory trace in the insect brain? *J Neurosci*, 30, 6461-6465.
- Humphrey, N.K. (1976). The social function of intellect. *Growing points in ethology*, 37, 303-317.
- Ito, H., Fujitani, K., Usui, K., Shimizu-Nishikawa, K., Tanaka, S., and Yamamoto, D. (1996). Sexual orientation in *Drosophila* is altered by the satori mutation in the sex-determination gene fruitless that encodes a zinc finger protein with a BTB domain. *Proceedings of the National Academy of Sciences of the United States of America*, 93, 9687.
- Jain, R., and Brockmann, A. (2020). Sex-specific molecular specialization and activity rhythm-dependent gene expression in honey bee antennae. *Journal of Experimental Biology*, 223,

- Jefferis, G.S., Potter, C.J., Chan, A.M., Marin, E.C., Rohlffing, T., Maurer, C.R., Jr., and Luo, L. (2007). Comprehensive maps of *Drosophila* higher olfactory centers: spatially segregated fruit and pheromone representation. *Cell*, 128, 1187-1203.
- Joerges, J., Küttner, A., Galizia, C.G., and Menzel, R. (1997). Representations of odours and odour mixtures visualized in the honeybee brain. *Nature*, 387, 285-288.
- Kamhi, J.F., Ilies, I., and Traniello, J.F.A. (2019). Social Complexity and Brain Evolution: Comparative Analysis of Modularity and Integration in Ant Brain Organization. *Brain Behav Evol*, 93, 4-18.
- Kather, R., Drijfhout, F.P., and Martin, S.J. (2011). Task Group Differences in Cuticular Lipids in the Honey Bee *Apis mellifera*. *Journal of Chemical Ecology*, 37, 205-212.
- Kimura, K.I., Hachiya, T., Koganezawa, M., Tazawa, T., and Yamamoto, D. (2008). Fruitless and Doublesex Coordinate to Generate Male-Specific Neurons that Can Initiate Courtship. *Neuron*, 59, 759-769.
- Kimura, K.I., Ote, M., Tazawa, T., and Yamamoto, D. (2005). Fruitless specifies sexually dimorphic neural circuitry in the *Drosophila* brain. *Nature*, 438, 229-233.
- Koeniger G, K.N., Ellis J, Connor L J (2014). Mating biology of honey bees (*Apis mellifera*).
- Koeniger, N., and Koeniger, G. (2004). Mating behavior in honey bees (*Apis*). *Tropical Agricultural Research and Extension*, 7, 13-28.
- Koeniger, N., Koeniger, G., Gries, M., and Tingek, S. (2005). Drone competition at drone congregation areas in four *Apis* species. *Apidologie*, 36, 211-221.
- Kopp, A., Duncan, I., Godt, D., and Carroll, S.B. (2000). Genetic control and evolution of sexually dimorphic characters in *Drosophila*. *Nature*, 408, 553-559.
- Kovac, H., Stabentheiner, A., and Brodschneider, R. (2009). Contribution of honeybee drones of different age to colonial thermoregulation. *Apidologie*, 40, 82-95.
- Kyrou, K., Hammond, A.M., Galizi, R., Kranjc, N., Burt, A., Beaghton, A.K., Nolan, T., and Crisanti, A. (2018). A CRISPR–Cas9 gene drive targeting doublesex causes complete population suppression in caged *Anopheles gambiae* mosquitoes. *Nature Biotechnology*, 36, 1062-1066.
- Lee, G., Foss, M., Goodwin, S.F., Carlo, T., Taylor, B.J., and Hall, J.C. (2000). Spatial, Temporal, and Sexually Dimorphic Expression Patterns of the fruitless Gene in the *Drosophila* Central Nervous System. *J Neurobiol*, 43, 404-426.
- Lensky, Y., Cassier, P., Notkin, M., Delorme-Joulie, C., and Levinsohn, M. (1985). Pheromonal activity and fine structure of the mandibular glands of honeybee drones (*Apis mellifera* L.) (Insecta, Hymenoptera, Apidae). *Journal of Insect Physiology*, 31, 265-276.
- Lindauer, M., and Watkin, B. (1953). Division of labour in the honeybee colony. *Bee world*, 34, 63-73.
- Mariette, J., Carcaud, J., and Sandoz, J.C. (2021). The neuroethology of olfactory sex communication in the honeybee *Apis mellifera* L. *Cell and Tissue Research*, 383, 177-194.
- Meier, N., Kappeli, S.C., Hediger Niessen, M., Billeter, J.C., Goodwin, S.F., and Bopp, D. (2013). Genetic control of courtship behavior in the housefly: evidence for a conserved bifurcation of the sex-determining pathway. *PLoS One*, 8, e62476.

- Menzel, R. (1999). Memory dynamics in the honeybee. *Journal of Comparative Physiology*, 185, 323-340.
- Menzel, R. (2012). The honeybee as a model for understanding the basis of cognition. *Nature Reviews Neuroscience*, 13, 758-768.
- Menzel, R., and Giurfa, M. (2001). Cognitive architecture of a mini-brain: the honeybee. *Trends in Cognitive Sciences*, 5, 62-71.
- Milyaev, N., Osumi-Sutherland, D., Reeve, S., Burton, N., Baldock, R.A., and Armstrong, J.D. (2012). The Virtual Fly Brain browser and query interface. *Bioinformatics*, 28, 411-415.
- Mobbs, P.G. (1982). The Brain of the Honeybee *Apis Mellifera*. I. The Connections and Spatial Organization of the Mushroom Bodies. *Philosophical Transactions of the Royal Society of London. Series B, Biological Sciences*, 298, 309-354.
- Mysore, K., Sun, L., Tomchaney, M., Sullivan, G., Adams, H., Piscocoya, A.S., Severson, D.W., Syed, Z., and Duman-Scheel, M. (2015). siRNA-Mediated Silencing of doublesex during Female Development of the Dengue Vector Mosquito *Aedes aegypti*. *PLoS Negl Trop Dis*, 9, e0004213.
- Netschitailo, O. (2020). Regulatory mechanisms underlying sexual differentiation in the honeybee.
- Nishino, H., Nishikawa, M., Mizunami, M., and Yokohari, F. (2009). Functional and topographic segregation of glomeruli revealed by local staining of antennal sensory neurons in the honeybee *Apis mellifera*. *J Comp Neurol*, 515, 161-180.
- Nissen, I., Müller, M., and Beye, M. (2012). The Am-tra2 gene is an essential regulator of female splice regulation at two levels of the sex determination hierarchy of the honeybee. *Genetics*, 192, 1015-1026.
- Page, R.E., and Erickson, E.H. (1988). Reproduction by worker honey bees (*Apis mellifera* L.). *Behavioral Ecology and Sociobiology*, 23, 117-126.
- Page, R.E., Metcalf, R.A., Metcalf, R.L., Erickson, E.H., and Lampman, R.L. (1991). Extractable hydrocarbons and kin recognition in honeybee (*Apis mellifera* L.). *Journal of chemical ecology*, 17, 745-756.
- Pankiw, T., Winston, M.L., Plettner, E., Slessor, K.N., Pettis, J.S., and Taylor, O.R. (1996). Mandibular gland components of european and africanized honey bee queens (*Apis mellifera* L.). *J Chem Ecol*, 22, 605-615.
- Pérez-Barbería, F.J., Shultz, S., and Dunbar, R.I. (2007). Evidence for coevolution of sociality and relative brain size in three orders of mammals. *Evolution*, 61, 2811-2821.
- Rein, K., Zöckler, M., Mader, M.T., Grübel, C., and Heisenberg, M. (2002). The *Drosophila* standard brain. *Curr Biol*, 12, 227-231.
- Rhodes, J., and Lacey, M. (2007). Changes with age in queen honey bee (*Apis mellifera*) head chemical constituents (Hymenoptera : Apidae). *Sociobiology*, 50, 11-22.
- Rice, G.R., Barmina, O., Luecke, D., Hu, K., Arbeitman, M., and Kopp, A. (2019). Modular tissue-specific regulation of doublesex underpins sexually dimorphic development in *Drosophila*. *Development*, 146, dev178285.
- Robertson, H.M., and Wanner, K.W. (2006). The chemoreceptor superfamily in the honey bee, *Apis mellifera*: expansion of the odorant, but not gustatory, receptor family. *Genome research*, 16, 1395-1403.
- Robertson, H.M., Warr, C.G., and Carlson, J.R. (2003). Molecular evolution of the insect chemoreceptor gene superfamily in *Drosophila melanogaster*. *Proc Natl Acad Sci U S A*, 100 Suppl 2, 14537-14542.

- Rösch, G. (1925). Untersuchungen über die Arbeitsteilung im Bienenstaat. 1. Teil: Die Tätigkeiten im normalen Bienenstaat und ihre Beziehungen zum Alter der Arbeitsbienen. *Z. vergl. Physiol*, 2, 571-631.
- Roth, A., Vleurinck, C., Netschitailo, O., Bauer, V., Otte, M., Kaftanoglu, O., Page, R.E., and Beye, M. (2019). A genetic switch for worker nutrition-mediated traits in honeybees. *PLOS Biology*, 17, e3000171.
- Roussel, E., Carcaud, J., Combe, M., Giurfa, M., and Sandoz, J.-C. (2014). Olfactory coding in the honeybee lateral horn. *Current biology*, 24, 561-567.
- Rybak, J., Kuß, A., Lamecker, H., Zachow, S., Hege, H.-C., Lienhard, M., Singer, J., Neubert, K., and Menzel, R. (2010). The digital bee brain: integrating and managing neurons in a common 3D reference system. *Frontiers in systems neuroscience*, 4, 30.
- Ryner, L.C., Goodwin, S.F., Castrillon, D.H., Anand, A., Vilella, A., Baker, B.S., Hall, J.C., Taylor, B.J., and Wasserman, S.A. (1996). Control of male sexual behavior and sexual orientation in *Drosophila* by the fruitless gene. *Cell*, 87, 1079-1089.
- Sachse, S., Rappert, A., and Galizia, C.G. (1999). The spatial representation of chemical structures in the antennal lobe of honeybees: steps towards the olfactory code. *Eur J Neurosci*, 11, 3970-3982.
- Salvemini, M., D'Amato, R., Petrella, V., Aceto, S., Nimmo, D., Neira, M., Alphey, L., Polito, L.C., and Saccone, G. (2013). The orthologue of the fruitfly sex behaviour gene fruitless in the mosquito *Aedes aegypti*: evolution of genomic organisation and alternative splicing. *PLoS One*, 8, e48554.
- Sandoz, J.C. (2006). Odour-evoked responses to queen pheromone components and to plant odours using optical imaging in the antennal lobe of the honey bee drone *Apis mellifera* L. *Journal of Experimental Biology*, 209, 3587-3598.
- Sato, K., Goto, J., and Yamamoto, D. (2019). Sex Mysteries of the Fly Courtship Master Regulator Fruitless. *Frontiers in Behavioral Neuroscience*, 13, 245.
- Schlüns, H., Moritz, R.F.A., Neumann, P., Kryger, P., and Koeniger, G. (2005). Multiple nuptial flights, sperm transfer and the evolution of extreme polyandry in honeybee queens. *Animal Behaviour*, 70, 125-131.
- Scott, K., Brady, R., Jr., Cravchik, A., Morozov, P., Rzhetsky, A., Zuker, C., and Axel, R. (2001). A chemosensory gene family encoding candidate gustatory and olfactory receptors in *Drosophila*. *Cell*, 104, 661-673.
- Seeley, T.D. (1986). Division of labour among worker honeybees.
- Seeley, T.D. (1995). The wisdom of the hive : the social physiology of honey bee colonies. *Harvard University Press*.
- Song, H.J., Billeter, J.C., Reynaud, E., Carlo, T., Spana, E.P., Perrimon, N., Goodwin, S.F., Baker, B.S., and Taylor, B.J. (2002). The fruitless gene is required for the proper formation of axonal tracts in the embryonic central nervous system of *Drosophila*. *Genetics*, 162, 1703.
- Stockinger, P., Kvitsiani, D., Rotkopf, S., Tirián, L., and Dickson, B.J. (2005). Neural circuitry that governs *Drosophila* male courtship behavior. *Cell*, 121, 795-807.
- Strutz, A., Soelter, J., Baschwitz, A., Farhan, A., Grabe, V., Rybak, J., Knaden, M., Schmuker, M., Hansson, B.S., and Sachse, S. (2014). Decoding odor quality and intensity in the *Drosophila* brain. *eLife*, 3, e04147.
- Sun, X.-J., Fonta, C., and Masson, C. (1993). Odour quality processing by bee antennal lobe interneurons. *Chemical Senses*, 18, 355-377.
- Thiagarajan, D., and Sachse, S. (2022). Multimodal Information Processing and Associative Learning in the Insect Brain. *Insects*, 13, 332.

- Usui-Aoki, K., Ito, H., Ui-Tei, K., Takahashi, K., Lukacsovich, T., Awano, W., Nakata, H., Piao, Z.F., Nilsson, E.E., Tomida, J.Y., and Yamamoto, D. (2000). Formation of the male-specific muscle in female *Drosophila* by ectopic fruitless expression. *Nature Cell Biology* 2:8, 2, 500-506.
- van Zweden, J.S., and d'Ettoire, P. (2010). Nestmate recognition in social insects and the role of hydrocarbons. *Insect hydrocarbons: biology, biochemistry and chemical ecology*, 11, 222-243.
- Villar, G., Hefetz, A., and Grozinger, C.M. (2019). Evaluating the Effect of Honey Bee (*Apis mellifera*) Queen Reproductive State on Pheromone-Mediated Interactions with Male Drone Bees. *J Chem Ecol*, 45, 588-597.
- Vosshall, L.B., Amrein, H., Morozov, P.S., Rzhetsky, A., and Axel, R. (1999). A spatial map of olfactory receptor expression in the *Drosophila* antenna. *Cell*, 96, 725-736.
- Vosshall, L.B., Wong, A.M., and Axel, R. (2000). An olfactory sensory map in the fly brain. *Cell*, 102, 147-159.
- Wachsmann, A., and Crailsheim, K. (1994). 36. Das Verhalten junger Drohnen (*Apis mellifera carnica* Pollm) im Stock. *Apidologie*, 25, 465-466.
- Wakonigg, G., Eveleigh, L., Arnold, G., and Crailsheim, K. (2000). Cuticular hydrocarbon profiles reveal age-related changes in honey bee drones (*Apis mellifera carnica*). *Journal of Apicultural Research*, 39, 137-141.
- Wanner, K.W., Nichols, A.S., Walden, K.K.O., Brockmann, A., Luetje, C.W., and Robertson, H.M. (2007). A honey bee odorant receptor for the queen substance 9-oxo-2-decenoic acid. *Proceedings of the National Academy of Sciences of the United States of America*, 104, 14383-14388.
- Weaverdyck, M.E., and Parkinson, C. (2018). The neural representation of social networks. *Curr Opin Psychol*, 24, 58-66.
- Williams, T.M., Selegue, J.E., Werner, T., Gompel, N., Kopp, A., and Carroll, S.B. (2008). The regulation and evolution of a genetic switch controlling sexually dimorphic traits in *Drosophila*. *Cell*, 134, 610-623.
- Winston, M.L. (1987). The biology of the honey bee. *Harvard University Press*.
- Witthöft, W. (1967). Absolute Anzahl und Verteilung der Zellen im Hirn der Honigbiene. *Zeitschrift für Morphologie der Tiere*, 61, 160-184.
- Woyke, J. (1955). Multiple mating of the honeybee queen (*Apis mellifica* L) in one nuptial flight. *Bull. Acad. Polon. Sci. Cl*, 3, 175-180.
- Xu, J., Liu, W., Yang, D., Chen, S., Chen, K., Liu, Z., Yang, X., Meng, J., Zhu, G., Dong, S., et al. (2020). Regulation of olfactory-based sex behaviors in the silkworm by genes in the sex-determination cascade. *PLOS Genetics*, 16, e1008622.
- Xu, J., Zhan, S., Chen, S., Zeng, B., Li, Z., James, A.A., Tan, A., and Huang, Y. (2017). Sexually dimorphic traits in the silkworm, *Bombyx mori*, are regulated by doublesex. *Insect Biochem Mol Biol*, 80, 42-51.
- Zhuo, J.C., Hu, Q.L., Zhang, H.H., Zhang, M.Q., Jo, S.B., and Zhang, C.X. (2018). Identification and functional analysis of the doublesex gene in the sexual development of a hemimetabolous insect, the brown planthopper. *Insect Biochem Mol Biol*, 102, 31-42.
- Zollman, S., Godt, D., Privé, G.G., Couderc, J.L., and Laski, F.A. (1994). The BTB domain, found primarily in zinc finger proteins, defines an evolutionarily conserved family that includes several developmentally regulated genes in *Drosophila*. *Proceedings of the National Academy of Sciences of the United States of America*, 91, 10717-10721.

## Danksagung

An dieser Stelle möchte ich mich bei all denjenigen bedanken, die mich während der Anfertigung dieser Arbeit unterstützt und motiviert haben.

Zuerst gebührt mein Dank Prof. Dr. Martin Beye für die Betreuung dieser Arbeit, die vielen hilfreichen Diskussionen und die konstruktive Kritik bei der Erstellung dieser Arbeit.

Prof. Dr. Laura Rose danke ich für die Betreuung der Arbeit als Mentorin und Zweitgutachterin.

Mein besonderer Dank gilt meiner Familie, insbesondere meiner Frau Hannah, für die unentwegte Motivation und Unterstützung.

Vielen Dank an die gesamte Bienengruppe und die ehemaligen Mitarbeiterinnen Eva Theilenberg, Dr. Vivien Sommer und Dr. Oksana Netschitailo für die angenehme Arbeitsatmosphäre, die konstruktive Zusammenarbeit, die ständige Hilfsbereitschaft und moralische Unterstützung.